

**TOP VIEW**

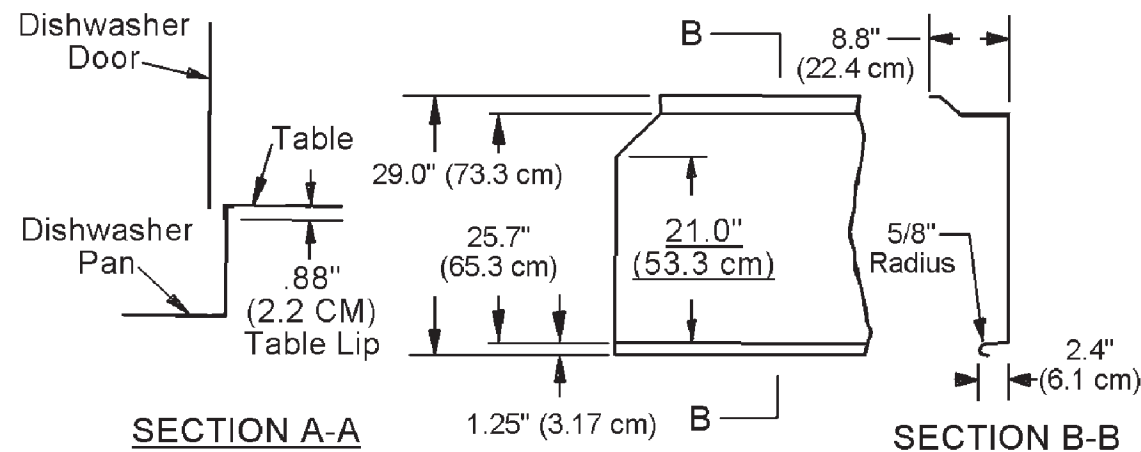

**TOP VIEW**  
TYPICAL TABLE DETAILS

**CAUTION:**  
Electrical and plumbing connections should be made by a qualified Service Person who will comply with all available federal, state, and local Health, Electrical, Plumbing, and Safety codes.

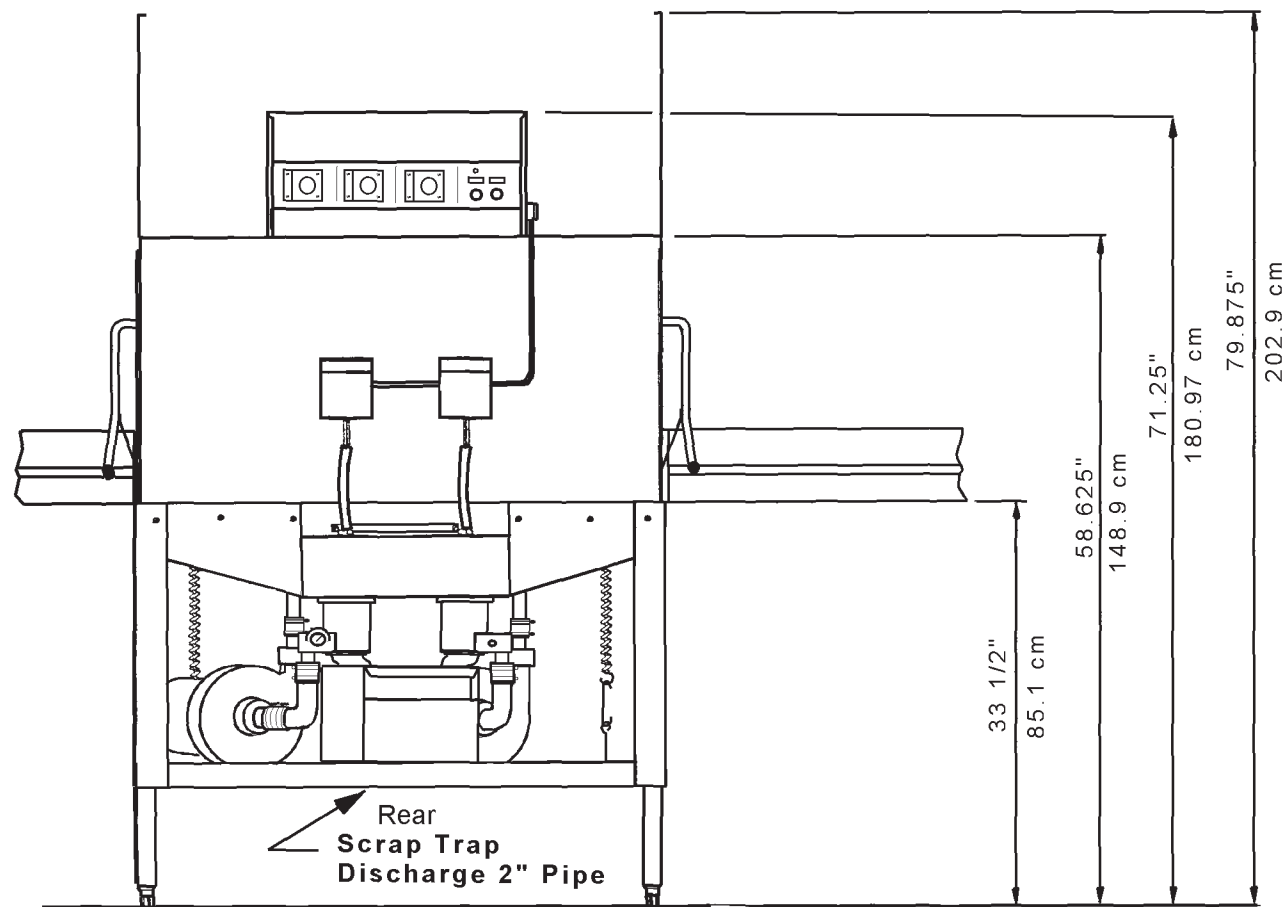

**FRONT VIEW**

**NOTE:**  
\*Manufacturer reserves the right to modify these specifications in compliance with regulatory agencies and manufacturing expediency

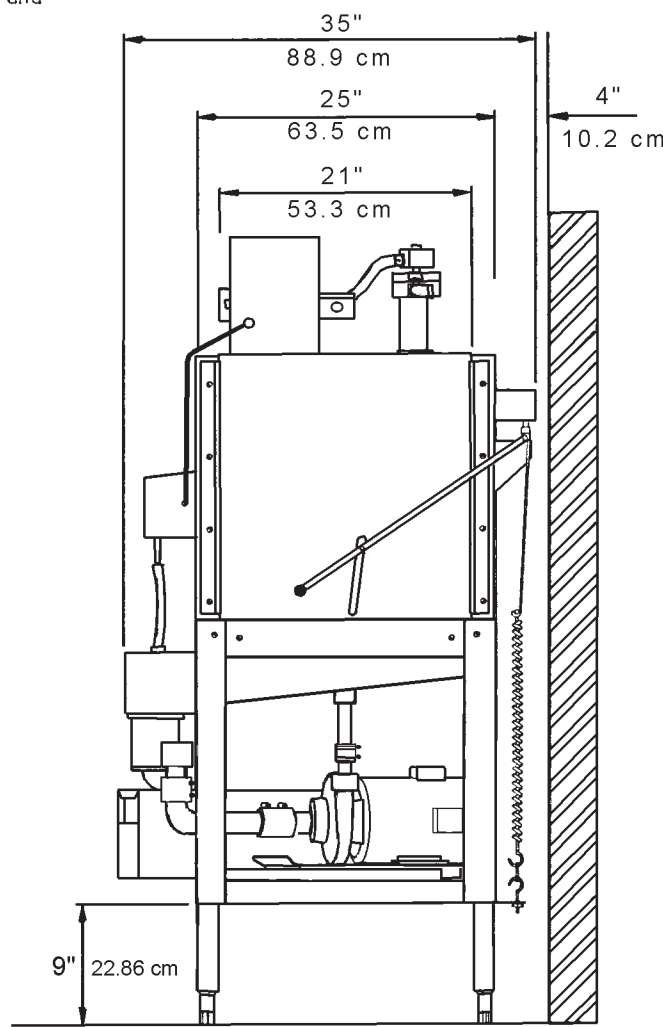

**SIDE VIEW**



**American Dish Service**  
Manufacturers of Ware Washing Equipment

**Model 5AGES**  
**Specifications**



|  |    |     |     |
|--|----|-----|-----|
| <b>RATED CAPACITY (Racks Per Hour)</b> | 74 | 56  | 46  |
| <b>WASH TIME (Sec.)</b>                | 50 | 60  | 75  |
| <b>RINSE TIME (Sec.)</b>               | 7  | 45  | 60  |
| <b>DWELL (Sec.)</b>                    |    | 15  | 15  |
| <b>TOTAL CYCLE TIME (Sec.)</b>         | 90 | 120 | 150 |

|                                  |   |
|----------------------------------|---|
| <b>WASH TANK CAPACITY (Min.)</b> | 1.78 Gallons<br>6.74 Liters                     |
| <b>WATER TEMPERATURE</b>         | 120 Deg. F Min.<br>49 Deg. C Min.               |
| <b>WATER CONSUMPTION</b>         | 1.78 Gallons Per Cycle<br>6.74 Liters Per Cycle |
| <b>MOTOR (2)</b>                 | 1.0 HP<br>.75 KW                                |
| <b>ELECTRICAL RATINGS</b>        | 115 Volts<br>18 Amp Single Phase                |

**CONNECT TO ELECTRICAL SUPPLY SOURCE**  
Using 10-8 AWG Copper Wire  
Circuit Protection: 30 AMP Circuit Breaker  
or Fuse with a 30 AMP Rating

|                                   |                                     |
|-----------------------------------|-------------------------------------|
| <b>RACK SIZE (2)</b>              | 19 3/4" x 19 3/4"<br>50.2 x 50.2 cm |
| <b>DOOR CLEARANCE</b>             | 20 1/2" x 21"<br>52.07 x 53 cm      |
| <b>WATER INLET</b>                | 3/4" FPT                            |
| <b>DRAIN (Scrap Trap)</b>         | 2" Pipe                             |
| <b>HEIGHT (Doors Open)</b>        | 79.875"                             |
| <b>HEIGHT (Doors Closed)</b>      | 71.25"                              |
| <b>WIDTH (Overall)</b>            | 49"                                 |
| <b>DEPTH (Overall)</b>            | 124.5 cm<br>34"                     |
| <b>SHIPPING WEIGHT</b>            | 86.4 cm<br>408 lbs.<br>185 kg       |
| <b>SHIPPING VOLUME (Uncrated)</b> | 64.16 cu ft.<br>1.82 cu m           |