



American Dish Service
Manufacturers of Ware Washing Equipment

WWW.AMERICANDISH.COM

3D-S Series

FAMILY MODELS
AF-3DS AH-3DS
AFC-3DS AHC-3DS

RATED CAPACITY (Racks/Hr.)	37	23
WASH TIME (Sec.)	45	75
RINSE TIME (Sec.)	30	60
DWELL (Sec.)	15	15
TOTAL CYCLE TIME (Sec.)	90	150

WATER TEMPERATURE (Supply) 120° F Min.
49° C Min.

WATER CONSUMPTION 2.2 Gal's Per Cycle
8.3 Liters Per Cycle

MOTOR 1.5 HP
1.125 KW

ELECTRICAL RATINGS 115 Volts
Single Phase

Connect to Supply Source using 10-12 AWG copper wires. Circuit Protection: 20 AMP Circuit Breaker or Fuse with a 20 AMP Rating.

RACK SIZE 19 3/4" x 19 3/4"
50.2 cm x 50.2 cm
DOOR CLEARANCE 20 3/4" x 20 1/2"
52.7 cm x 52.1 cm

WATER INLET 1/2" F.P.T.
DRAIN (Scrap Trap) 2" Pipe
HEIGHT (Door Open) 80 7/8"
205.4 cm

HEIGHT (Door Closed) 70 1/2"
179.1 cm

WIDTH (Overall) 33 1/2"
85.1 cm
WIDTH (Table to Table) 25"
63.5 cm

DEPTH (Overall) 34 1/4"
86.9 cm

SHIPPING WEIGHT 295 lb.
133.8 kg.

SHIPPING VOLUME 56.25 cu. ft.
1.59 cu meters

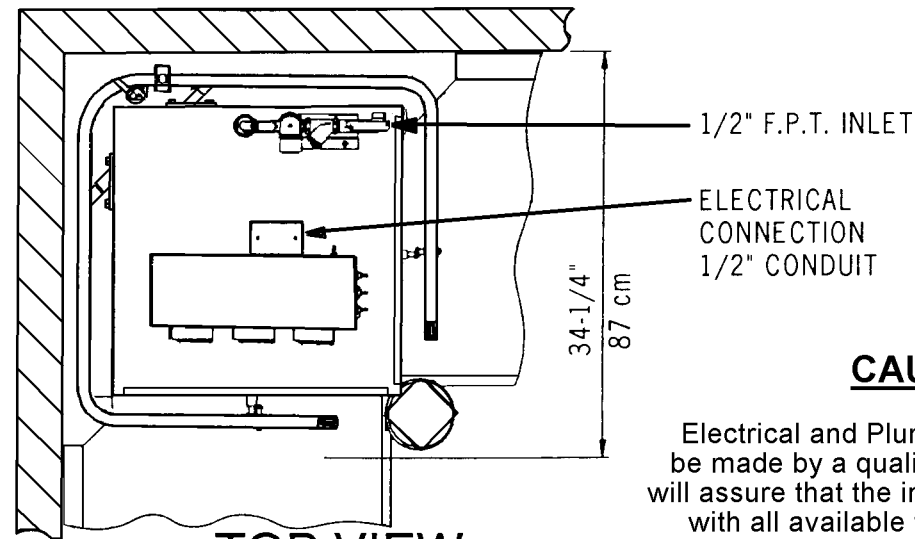

TOP VIEW
CORNER APPLICATION

CAUTION:

Electrical and Plumbing connections must be made by a qualified Service Person who will assure that the installation is in compliance with all available federal, state, and local Health, Electrical, Plumbing, and Safety codes.

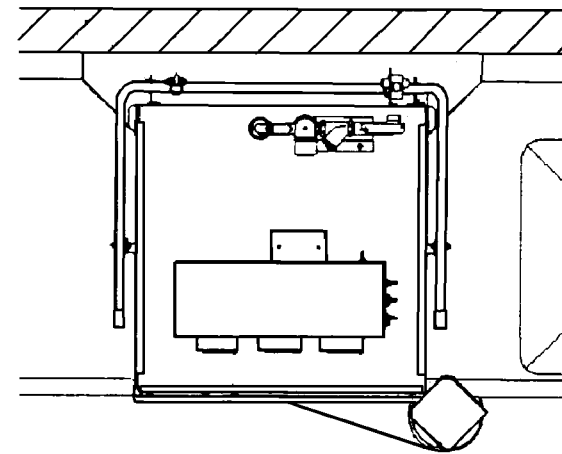

TOP VIEW
IN-LINE APPLICATION

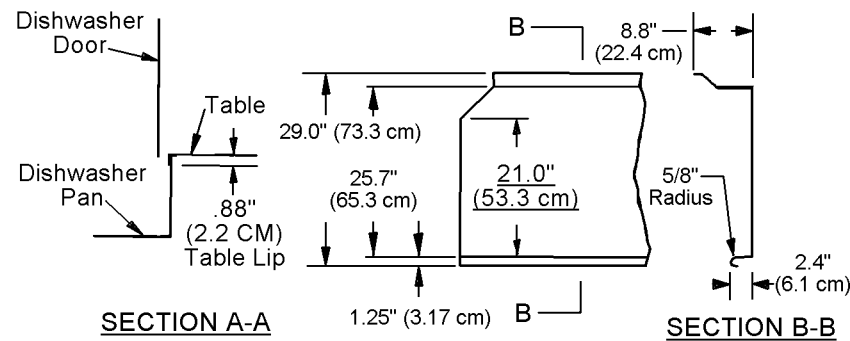

TOP VIEW
TYPICAL TABLE DETAILS

NOTE:
All dimensions listed have a tolerance of + or - 1/8" unless otherwise noted.

NOTE:

Manufacturer reserves the right to modify these specifications in compliance with regulatory agencies and manufacturing expediency.

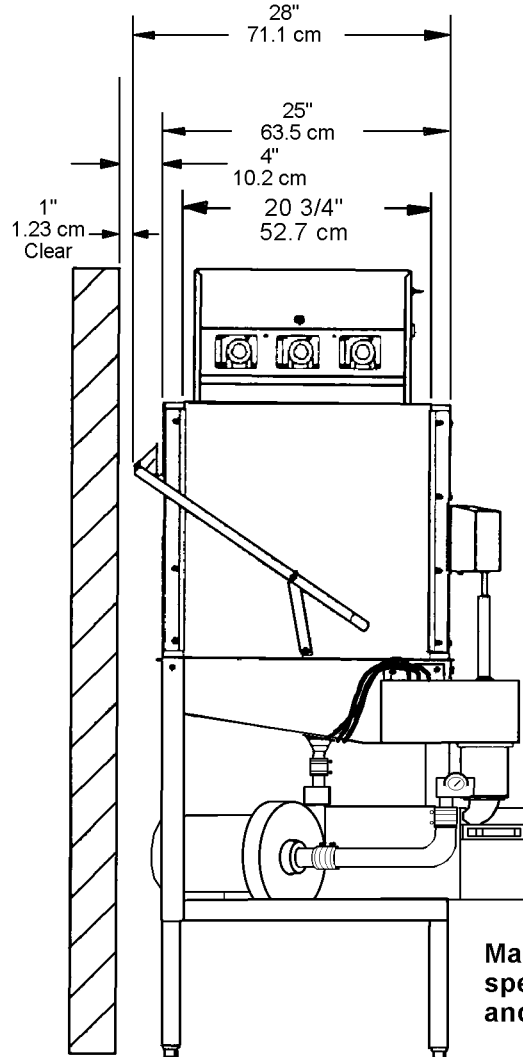

SIDE VIEW

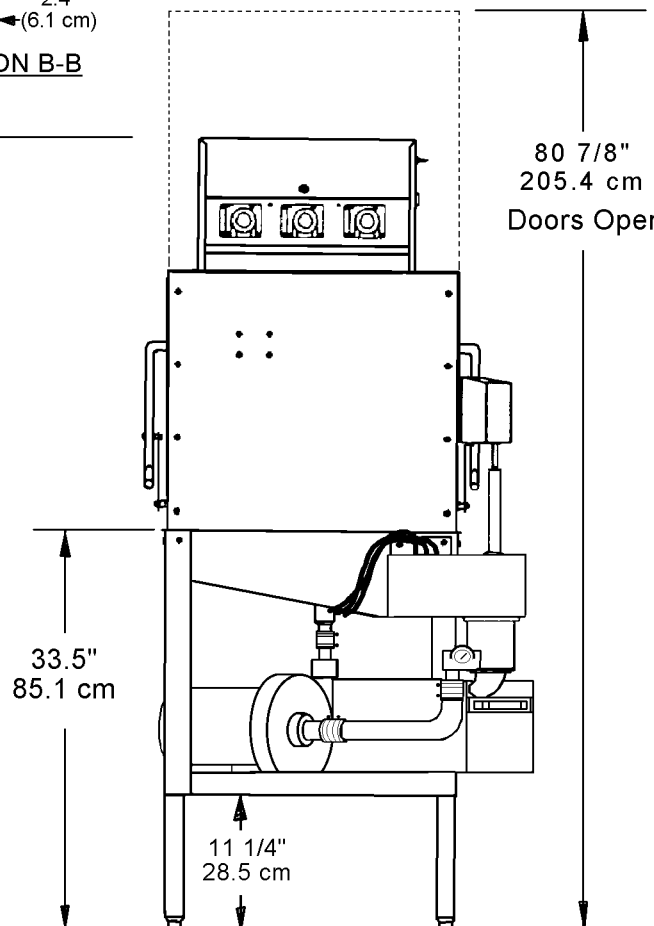

FRONT VIEW