

American Dish Service

Manufacturers of Ware Washing Equipment

WWW.AMERICANDISH.COM

AF/AFC-ES Series



AF-ES
AFC-ES

RATED CAPACITY (Racks/Hour)	37	25	12
WASH TIME (Sec.)	50	60	75
RINSE TIME (Sec.)	30	45	60
DWELL (Sec.)	10	15	15
TOTAL CYCLE TIME (Sec.)	90	120	150

WATER TEMPERATURE (Supply) 120° F Min.
49° C Min.

WATER CONSUMPTION .936 Gal's Per Cycle
3.543 Liters Per Cycle

MOTOR 1.5 HP
1.125 KW

ELECTRICAL RATINGS 115 Volts
Single Phase

Connect to Supply Source using 10-12 AWG copper wires. Circuit Protection: 20 AMP Circuit Breaker or Fuse with a 20 AMP Rating.

RACK SIZE 19 3/4" x 19 3/4"
50.2 cm x 50.2 cm

DOOR CLEARANCE 20 3/4" x 20 1/2"
52.7 cm x 52.1 cm

WATER INLET 1/2" F.P.T.
DRAIN (Scrap Trap) 2" Pipe

HEIGHT (Door Open) 80 1/4"
203.8 cm

HEIGHT (Door Closed) 71 1/2"
181.6 cm

WIDTH (Overall) 33 1/2"
85.1 cm

WIDTH (Table to Table) 25"
63.5 cm

DEPTH (Overall) 34 1/4"
86.9 cm

SHIPPING WEIGHT 295 lb.
133.8 kg.

SHIPPING VOLUME 56.25 cu. ft.
1.59 cu meters

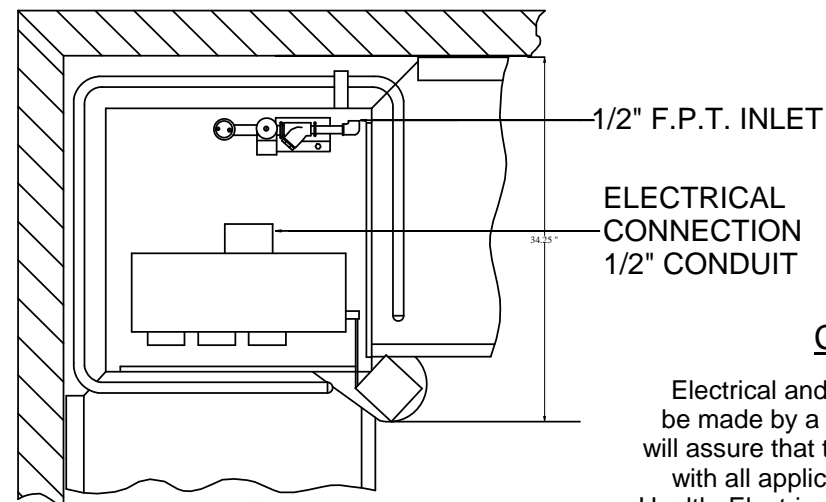

TOP VIEW
CORNER APPLICATION

CAUTION:

Electrical and Plumbing connections must be made by a qualified Service Person who will assure that the installation is in compliance with all applicable federal, state, and local Health, Electrical, Plumbing, and Safety Codes.

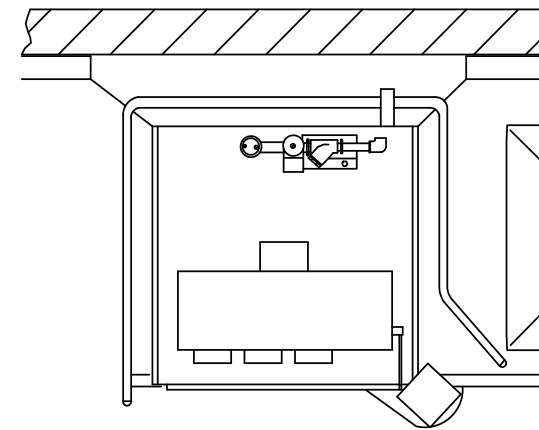

TOP VIEW
IN-LINE APPLICATION

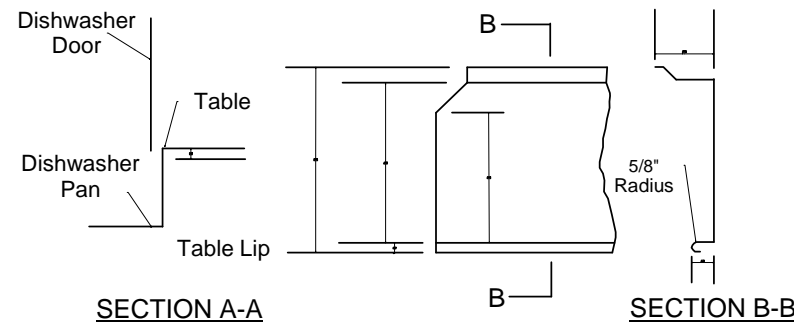

SECTION A-A **SECTION B-B**
TOP VIEW
TYPICAL TABLE DETAILS

NOTE:
All dimensions listed have a tolerance of + or - 1/8" unless otherwise noted.

NOTE:
Manufacturer reserves the right to modify these Specifications in compliance with regulatory agencies and manufacturing expediency.

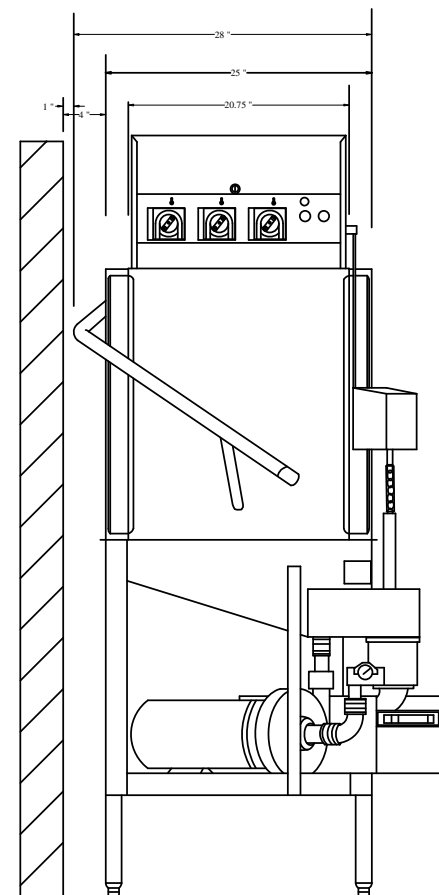

SIDE VIEW

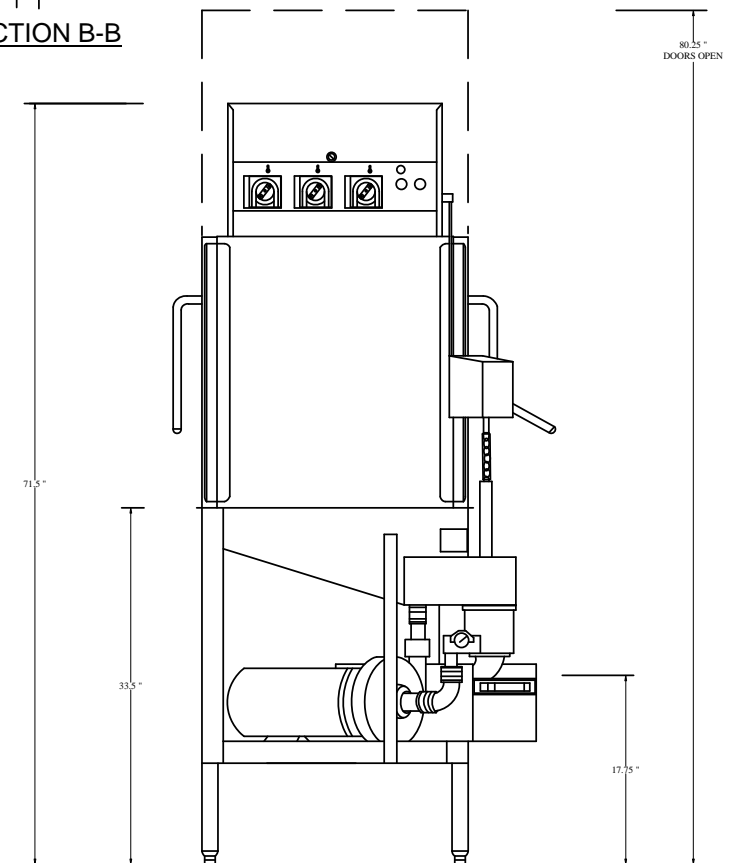

FRONT VIEW