

Model HT-25 Specifications

U.S. REGISTERED PATENTS

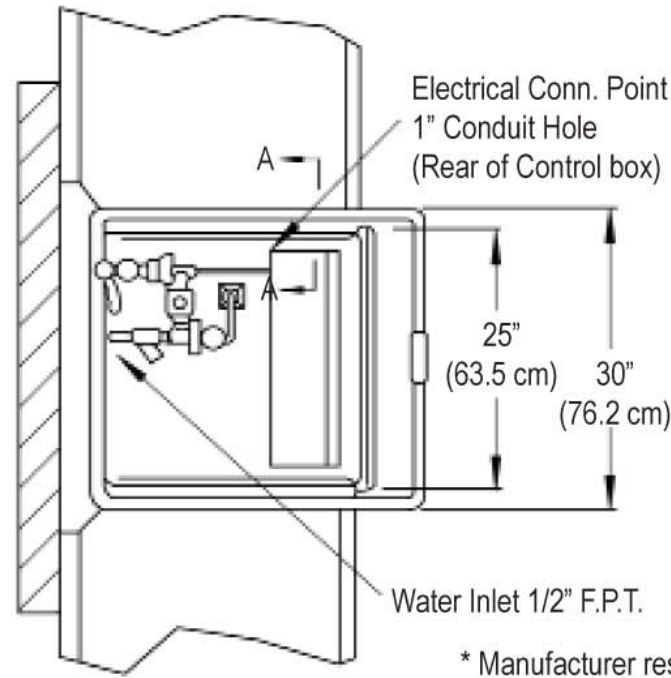

TOP VIEW

* Manufacturer reserves the right to modify these specifications in compliance with regulatory agencies and manufacturing expediency.

NOTE: All Three Doors Open in Unison for Inspection & Cleaning Purposes and Allows for Inline or Corner Applications without Conversion Procedures.

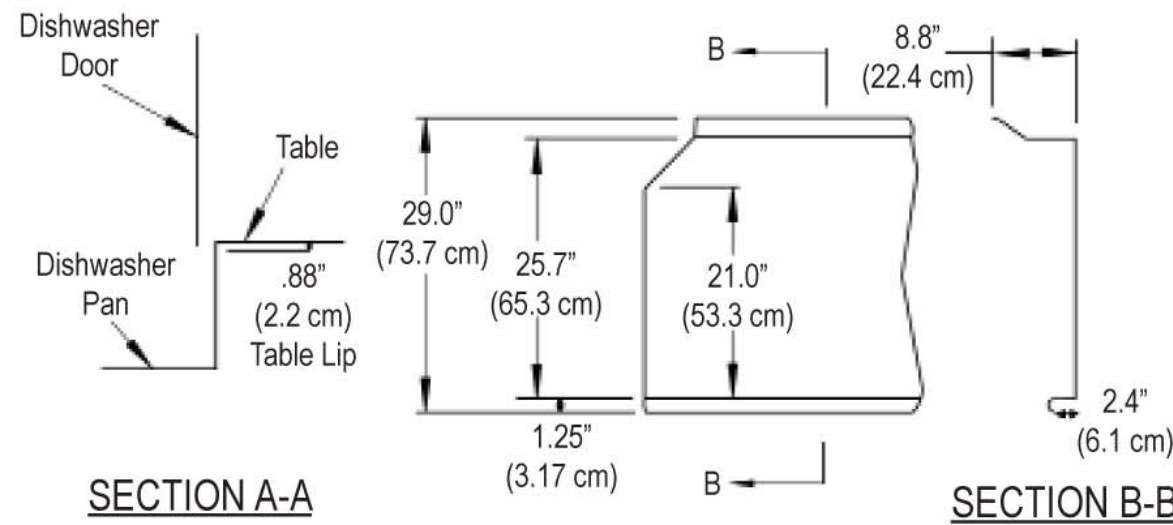

TOP VIEW
TYPICAL TABLE DETAILS

CAUTION:

Electrical and Plumbing connections must be made by a qualified Service Person who will comply with all available federal, state, and local Health, Electrical, Plumbing, and Safety Codes.

RATED CAPACITY (Racks/Hour)	72 NSF Rated
WASH TANK CAPACITY	11 Gal. (41.63 Liters)
WATER TEMPERATURE, WASH	160.0 F (71 C)
WATER TEMPERATURE, RINSE	180.0 F (82.2 C)
WATER CONSUMPTION	0.85 Gallons/Rack (3.593 Liters/Rack)
WASH MOTOR	3HP
ELECTRICAL REQUIREMENTS	3-PH, 208/240V, 40A, 60 Hz (4-Wire Connection, Three #8 Wires, Ground, 40A Breaker)

SINGLE PH, 208/240V, 90A, 60 Hz

(Dual Circuit: 30A Breaker, 60A Breaker, Neutral & Ground Wires)

COMBO OPTION: HT-25/34 W/Attached 12 kw Booster(3ph Only)

(4-Wire Connection, Three #8 Wires, Ground, 50A Breaker, Single-Point Connection Of Both The D/M & Booster)

NOTE: FOR HIGH TEMP SANITATION, A SEPARATE BOOSTER IS REQUIRED FOR THIS MODEL

WASH HEATER	8 KW
RACK SIZE	19-3/4" x 19-3/4" (50.2 cm x 50.2 cm)
DOOR CLEARANCE	18" (45.72 cm)

WATER INLET(1)	1/2" F.P.T.
DRAIN SIZE	2" F.P.T.
HEIGHT (All Doors Closed)	74" (187.96 cm)

WIDTH, TABLE TO TABLE (Inline Model)	25" (63.5 cm)
--------------------------------------	------------------

WIDTH W/SCRAP ACCUMULATOR (Overall)	37" (93.9 cm)
-------------------------------------	------------------

DEPTH (Overall)	33.5" (85.0 cm)
-----------------	--------------------

SHIPPING WEIGHT(STD/BoBooster)	460 Lbs./528 Lbs. (208.7 kg/239.5 kg)
--------------------------------	--

SHIPPING DIMENSIONS	49" L x 36" W x 82" H 124.5 cm x 91.4 cm x 208.3 cm
---------------------	--

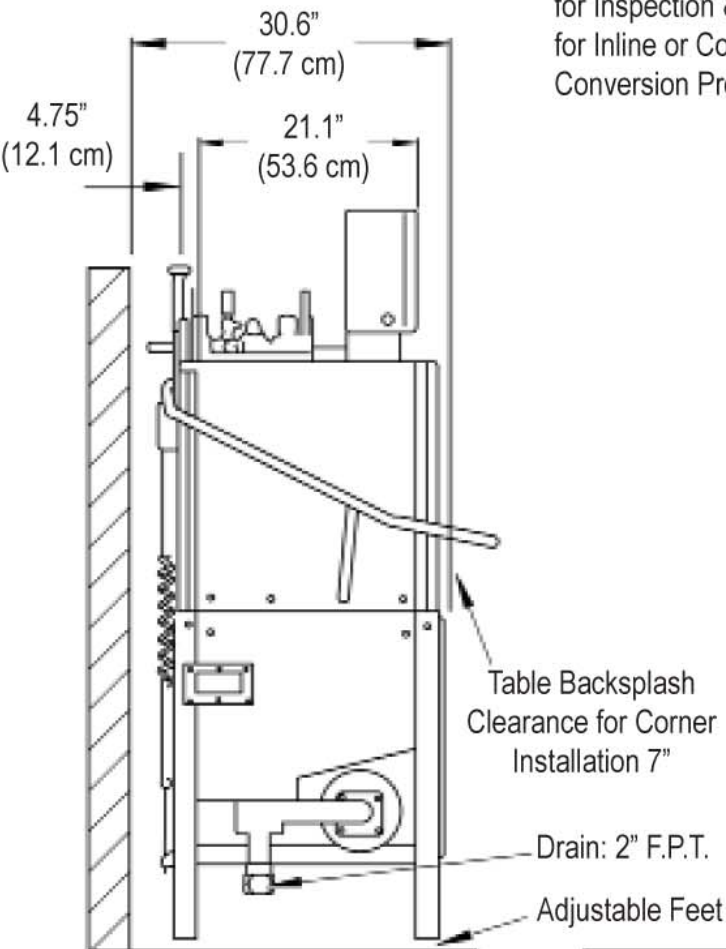

SIDE VIEW

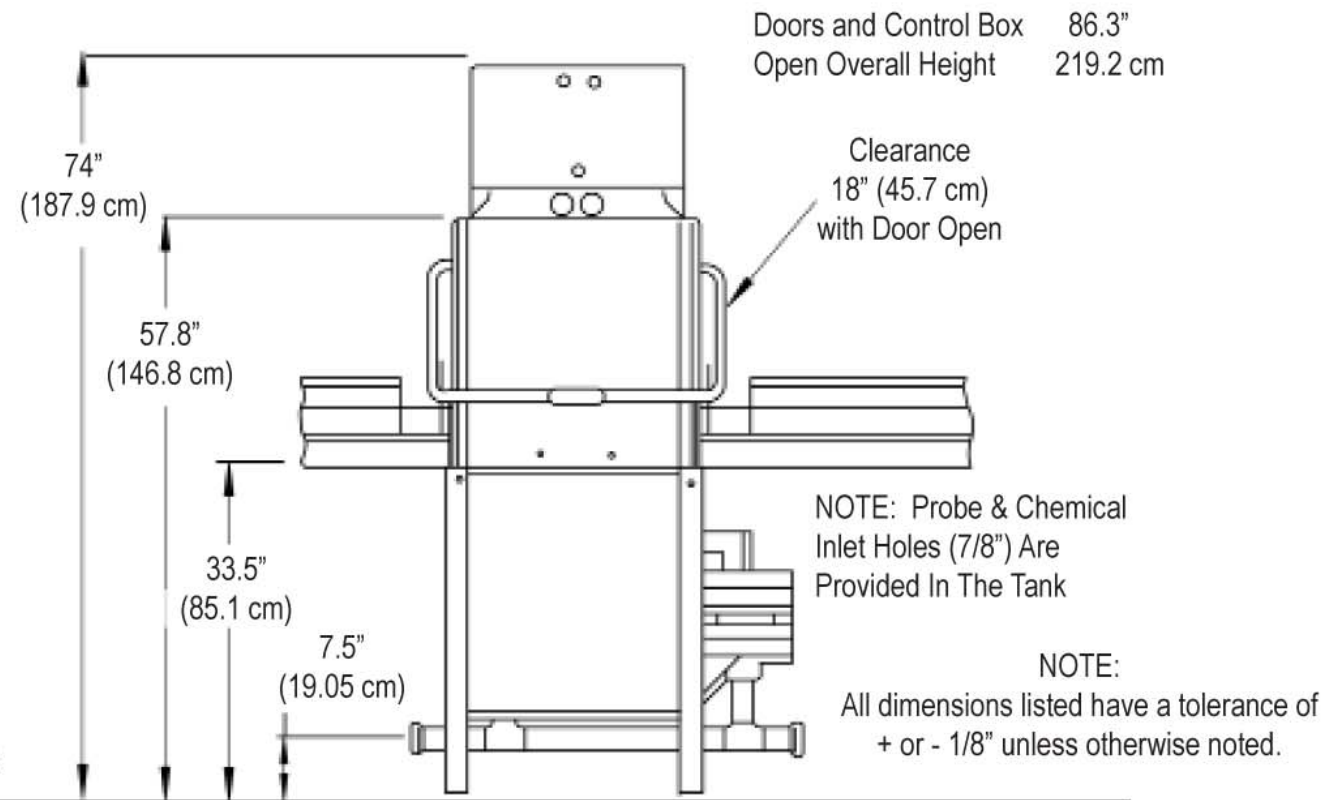

FRONT VIEW