

# ADC-44 TALL CONVEYOR



## HIGH\* or LOW Temp the Choice is Yours

Energy saving, high-capacity stage conveyor

### STANDARD FEATURES

- 244 racks per hour
- Operates ONLY when racks are inserted
- Unrivaled cleaning ability
- Dual rinsing system
- User friendly conveyor
- Uses as little as 0.49 gallons per rack

### Water Curtain Rinseability Equipped

- Activates prior to final rinse
- Initiates the rinsing process and acts as a shield between tanks



### Drain Pump Filter

- 2 stage pump strainer
- Eliminates wash pump obstructions and clogged jets
- Functions as drain stopper

### Dual - Fail Safe Heater Control

- Precise water control mechanism
- Only allows heaters to operate when tank is full
- Unaffected by heavy soil, water action, strong chemicals and lime build-up

### Captive End Caps

- Flip open, snap shut
- Shortens the cleaning process & eliminates down time



### Fail - Safe Conveyor System

- Eliminates damaged racks
- Slip clutch design - stops rack movement
- Once removed operation easily resumes



## American Dish Service

900 Blake Street | Edwardsville, Kansas, 66111  
Phone: 913.422.3700 | Toll-Free: 800.922.2178 | Fax: 913.422.6630  
orders@americandish.com | [americandish.com](http://americandish.com)

For detailed specifications, go to [www.americandish.com](http://www.americandish.com)

# ADC-44 TALL CONVEYOR

## Standard Features

- Auto fill
- No operator controls
- Energy saving stage washer
- Low water consumption
- No circuit boards
- Quiet operation
- Rack saving conveyor drive
- 244 racks per hour
- 360 sq. in. of washing action
- Auto cut-off
- High capacity heaters
- Self-purging
- Wide opening access doors
- 11 gallon wash tank with safety interlock
- 3 HP wash pump
- Skirted motor compartment
- Dual rinsing system
- Heavy stainless steel construction

All these features are Standard on the ADC-44 TALL. While other manufacturers may offer these same features as "Add-Ons" ... at American Dish our machines are **COMPLETE & READY TO RUN.**



## ADC-44 TALL Specifications

U.S. REGISTERED PATENTS

ADC-44 TALL	Family Models (left or right feed)	
	Hot Temp	Chemical
NSF Rated Capacity. . . . .	244 rack/hr	244 rack/hr
Conveyor Speed (ft/min) . . . . .	6.7 (2.04 M)	6.7 (2.04 M)
Water Consumption (Gal/Rack) . . . . .	0.49 (1.8 L)	0.49 (1.8 L)
Final Rinse Temperature (20 psi) . . . . .	180° F (82.2° C)	120° F (48.8° C)
Sanitizer (Water / Chlorine) . . . . .	180° F	50 ppm

Electrical Power Supply . . . . . **208/240V, 3PH, 60 AMP, 60HZ**  
*3 Phase installation requires 6 gauge wires, a suitable ground, and a clean circuit.*  
**1 PH, 50/60 AMP, 60 HZ**  
*1 Phase installation requires one (1) 50 AMP service using 8 gauge wires with a 10 gauge neutral wire, and one (1) 60 AMP service using 6 gauge wires and a suitable ground, both on clean circuits.*

Motor Ratings. . . . . 3 HP Wash, 1/3 HP Rinse, 1/3 HP Conveyor  
 Heater Ratings . . . . . 12 KW Wash, 2.25 KW Rinse

Rack Size . . . . . Standard 19.75" x 19.75" (50.2 x 50.2 cm)  
 Access Door Clearance . . . . . 21" x 24.5" (53.34 x 62.2 cm)  
 Rack Clearance (through machine) . . . . . 25.25" x 20.75" (64.13 x 52.7)  
 Water Inlet. . . . . 0.75" F.P.T.  
 Drain Size . . . . . 2.0" F.P.T.

Height (through machine) . . . . . 85.75" (217.81 cm)  
 (87.25" / 554.62 cm with control box open)

Width (overall) . . . . . 59.5" (151.13 cm)  
 Width, Table to Table . . . . . 44" (111.7 cm)  
 Depth . . . . . 30" (76.2 cm)

Shipping Weight . . . . . 780 lb (353.8 kg)  
 Shipping Volume (Crated) . . . . . 128.7 cu. ft. (3.64 cu. meters)

**RIGHT FEED**  
(W/O VENT OPTION)

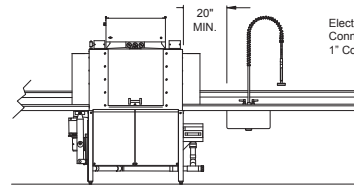

**TOP VIEW OF LEFT FEED**

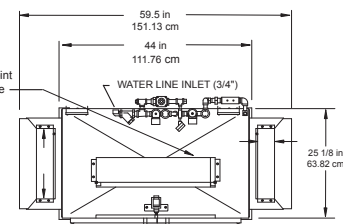

### IMPORTANT NOTES

Both clean and soiled tables are to be bolted to the dishmachine with the 1/4-20 x 1/2" bolts and nuts provided. Leaks cause potential problems in electrical and mechanical areas under the machine. Quick drains (table scuppers) are not compatible with stage type conveyor dishmachines. Scrap sinks shall be no closer than 20" minimum from the dishmachine end of the table. The clean exit table should be at least 72" straight for efficient conveyor operation.

Electrical and plumbing connections must be made by a qualified service person who will comply with all appropriate state and local health, electrical, plumbing, and safety codes. The Manufacturer reserves the right to modify these specifications in compliance with regulatory agencies and manufacturing expediency.

**NOTE:** All dimensions listed have a tolerance of (+) or (-) 1/8" unless otherwise noted.

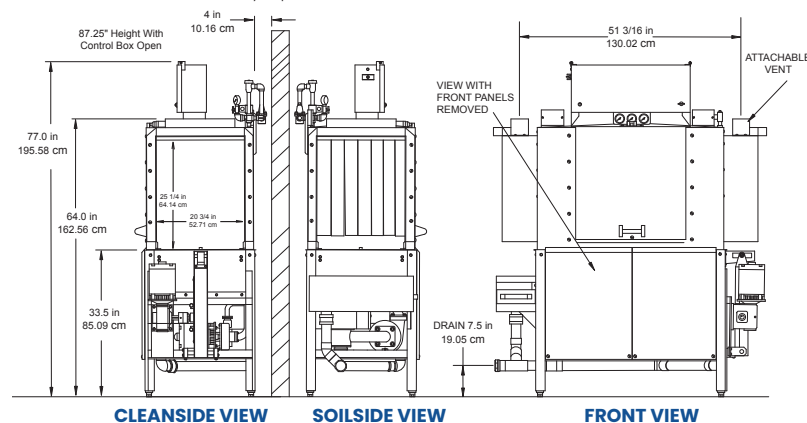
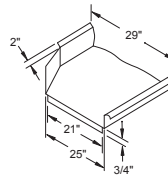

\*Requires external hot water source that will provide at least 120 gallons of 180 degree water an hour

Effective 2/2023

**Warning:** Cancer and Reproductive Harm - [www.P65Warnings.ca.gov](http://www.P65Warnings.ca.gov)



**American Dish Service**  
 Manufacturers of Ware Washing Equipment

an Ali Group Company



The Spirit of Excellence

**American Dish Service**

900 Blake Street | Edwardsville, Kansas, 66111  
 913.422.3700 | Toll-Free: 800.922.2178 | Fax: 913.422.6630  
[orders@americandish.com](mailto:orders@americandish.com) | [americandish.com](http://americandish.com)