

# HUB-40

## Undercounter High Temperature Dishwashing Machine with Built-in Booster Heater

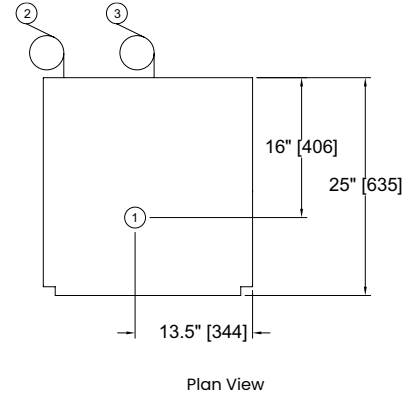
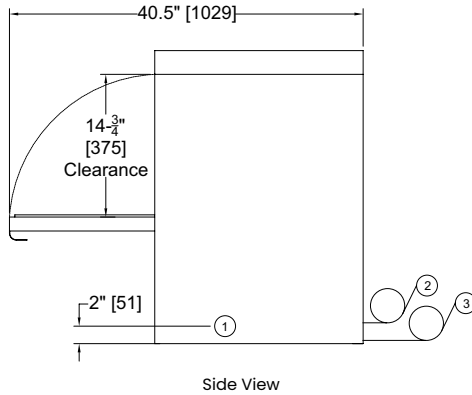
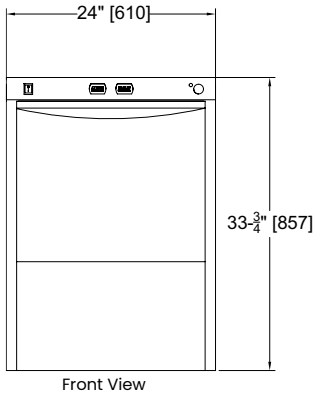

### SPECIFICATIONS

#### Capacities\*

Cycle time (seconds) . . . . . 90  
Racks per hr. . . . . 40

#### Motor horsepower

Wash . . . . . 1

#### Water consumption

U.S. Gal./Imperial Gal.  
(Max. use) per hr. . . . . 23.4/19.2  
U.S. Gal./Imperial Gal.  
per rack. . . . . 0.78/0.64

#### Temperatures °F/°C

Wash . . . . . 150/66  
Rinse . . . . . 180/82

#### Heating

Tank heat, electric, kW . . . . . 2.0

#### Time Cycle in Seconds

Wash . . . . . 70  
Rinse . . . . . 14  
Total cycle. . . . . 90

#### Standard 20" x 20" [508 x 508] Rack Complement

Dish . . . . . 1  
Open . . . . . 1  
\* at 140°F incoming water

### UTILITIES

#### 1 Electrical

208-240/60/1; 3 wire plus ground, (See Box).  
208-240/60/3; 4 wire plus ground, (See Box).  
Field convertible to accept 3 phase power, see service manual for details

#### 2 Hot Water

1/2" supply; 110°F/43°C Min. hot water connection for 70°F/39°C rise booster. Incoming supply pressure must maintain a Flow pressure of 20-22 PSI. Machine equipped with 3/4" [19] hose connector.

#### 3 Pumped Drain

5/8" [15.9] I.D. flexible reinforced hose, 6 ft. [1829] long.  
Max. drain flow 15 US gpm. [12.5 imp gal] Max. drain height 3 ft. [914]

#### 6kW HUB-40 with 70°F/39°C Booster Rise

Elec. Specs	Rated Amps	Minimum Supply Ckt. Conductor Ampacity	Maximum Overcurrent Protective Device
208/60/1	32	40	40
240/60/1	36	40	40
208/60/3	22	30	30
240/60/3	24	40	30

**Volume crated:** 15 cu. ft./0.42 cu.m

**Shipping weight crated:** 215 lbs./97.5 kg.

Dimensions shown in inches and [millimeters]

Due to an ongoing value analysis program, specifications contained in this catalog are subject to change without notice.

**Warning** Plumbing and electrical connections should be made by qualified personnel who will observe all the applicable plumbing, sanitary and safety codes and the National Electrical Code.

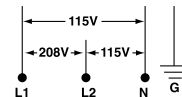

**Note:** Electrical supply service must be a 3-wire plus ground for connection shown.



an Ali Group Company



The Spirit of Excellence

### American Dish Service

900 Blake Street | Edwardsville, Kansas, 66111  
913.422.3700 | Toll-Free: 800.922.2178 | Fax: 913.422.6630  
orders@americandish.com | [americandish.com](http://americandish.com)

HUB40-V01-R1.0