

# Model 5AG-S TALL

**ADs**  
**American Dish Service**  
Manufacturers of Ware Washing Equipment

## High Capacity

Greater door clearance...  
washes taller wares

## STANDARD FEATURES

- Double duty rack model designed to multiply your dishwashing capabilities
- Air-gap fill
- Dual screens protect the pumps
- Washes 74 racks per hour with two powerful 1.5 HP pumps
- Large 27.5" door opening, wash taller wares



## Optional Pan Rack

Wash sheet pans vertically



## American Dish Service

900 Blake Street | Edwardsville, Kansas, 66111  
Phone: 913.422.3700 | Toll-Free: 800.922.2178 | Fax: 913.422.6630  
orders@americandish.com | [americandish.com](http://americandish.com)

For detailed specifications, go to  
[www.americandish.com](http://www.americandish.com)

# Model 5AG-S TALL

## High Capacity

### Standard Features

- Cleans 74 racks per hour
- Water consumption is 1.6 gallons per rack
- Tall door clearance at 27.5", 7" higher than standard
- Top mount controls with auto start
- Stainless steel air gap
- Quick release spray arms
- Two quick service 1.5 HP pumps
- Door safety switch and external prime switches
- Delime switch located in the control panel



### Model 5AG-S TALL Specifications

U.S. REGISTERED PATENTS

#### Standard 90 second timer, available 120 & 150 second timer

Rated Capacity (Racks/Hr.)	74	56	46
Wash Time (Sec.)	50	60	75
Rinse Time (Sec.)	30	45	60
Dwell (Sec.)	15	15	15
Total Cycle Time (Sec.)	90	120	150

Water Temperature (Supply) . . . . . 120° F Min. (49° C Min)  
 Water Consumption (Per Cycle) . . . . . 3.2 Gal. (12.1 Liter)

Motor (2) . . . . . 1.5 HP (1.125 Kw)  
 Electrical Ratings . . . . . 115 Volts (Single Phase)

Connect to two Supply Sources using 10-12 AWG copper wires. Circuit Protection: 20 AMP Circuit Breaker or Fuse with a 20 AMP Rating. **OR**

Connect to Supply Source using 8 AWG copper wires suitable for at least 167° F (75° C). Circuit Protection: 40 AMP Circuit Breaker or Fuse with a 40 AQPMP Rating.

Rack Size (2)	19.75" x 19.75v	(50.2 cm x 50.2 cm)
Door Clearance	27.5" x 21"	(69.85 cm x 53 cm)
Water Inlet		.075" FPT
Drain (Scrap Trap)		2.0" Pipe
Height (Door Open)	93.5"	(237.49 cm)
Height (Door Closed)	78"	(198.12 cm)
Width (Overall)	49"	(124.5 cm)
Width (Table to Table)	44"	(111.8 cm)
Depth (Overall)	34"	(86.4 cm)
Shipping Weight	446 lb.	(202.3 kg)
Shipping Dimensions	60" L x 36" W x 78" H	(152.4 cm x 91.4 cm x 198.1 cm)

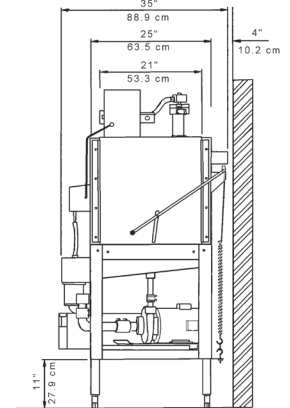
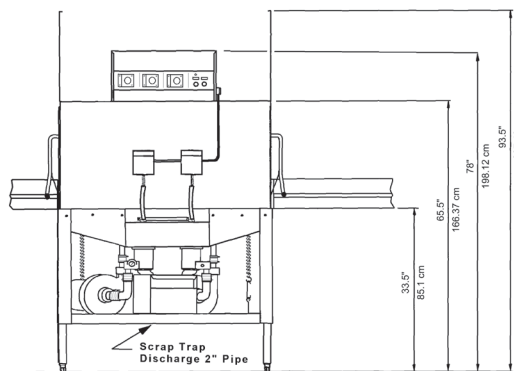
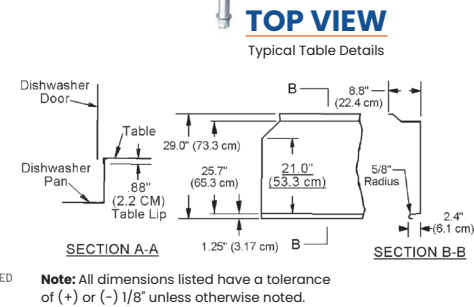
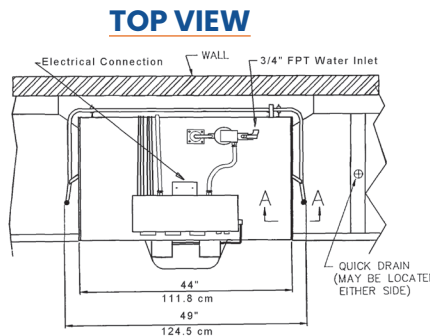

#### FRONT VIEW

#### SIDE VIEW

#### CAUTION:

Electrical and Plumbing connections must be made by a qualified Service Person who will comply with all available federal, state, and local Health, Electrical, Plumbing, and Safety Codes.

#### Note:

Manufacturer reserves the right to modify these specifications in compliance with regulatory agencies and manufacturing expediency.

Effective 2/2023



**Warning:** Cancer and Reproductive Harm – [www.P65Warnings.ca.gov](http://www.P65Warnings.ca.gov)



**American Dish Service**  
 Manufacturers of Ware Washing Equipment

an Ali Group Company



The Spirit of Excellence

**American Dish Service**

900 Blake Street | Edwardsville, Kansas, 66111  
 913.422.3700 | Toll-Free: 800.922.2178 | Fax: 913.422.6630  
[orders@americandish.com](mailto:orders@americandish.com) | [americandish.com](http://americandish.com)