

Effective: October 31, 2023



Model AWS, AWS-H

Available in 90, 120, 150-second Time Cycles

Front Door-type, Single-Rack, Chemical Sanitizer, Dump & Fill Dishmachine

Listed by UL #E68594, NSF/ANSI 3, ASSE 1004 #933, LA Test Labs File M-780089, Mass. License P3-0111-306

PARTS MANUAL



If you have questions, call 800-922-2178 or visit
our website at
www.americandish.com

American Dish Service

900 Blake Street | Edwardsville, Kansas 66111
Phone: 913.422.3700 | Toll-Free: 800.922.2178 | Fax: 913.422.6630
orders@americandish.com | americandish.com

Rev 1.0 © 10/2023

The **American Dish Service** part numbers contained in this publication are replacement parts for equipment listed with governmental and regulatory agencies and are specified to maintain the regulatory mark and certification. These parts must only be replaced by those who are trained in the operation and service of commercial dishmachines. Aftermarket parts or modified parts are not compliant or listed with the standards of governmental and regulatory agencies; aftermarket parts are not authorized by ADS for replacement repairs. ADS will not be responsible for any liability if parts are used in the repair of the machine that are not ADS-specified, by those installing non-certified replacement parts or attempts to change the machine's cycle or operation other than as designed and certified. **Read the warnings and cautions provided below before working on or replacing parts on any ADS equipment.**



DANGER

The installation of electrical parts contained in this publication require the following precautions:

The electrical power supplied to this machine is an imminent hazard to life that could result in severe bodily injury or death if not properly installed or connected correctly. When working in the control box or on electrical parts, always disconnect power and perform the appropriate lock-out/tag-out procedure before servicing. Replace the cover to the control box and other protective covers when finished with servicing this equipment before returning the machine to normal operation.

LOOSE ELECTRICAL CONNECTIONS: Damage to the equipment can occur if the following precautions are not observed. Before connecting power to the machine, check all electrical terminals in the control box. Screws can loosen in transit. Loose connections on high amp load terminals such as the pump motor and tank heaters will cause wire burning and component damage during operation and will not be covered under ADS warranty.

"CLEAN CIRCUIT" means the electrical circuit breaker for the dishmachine supplies no other outlets, machines, or lights. GFCI outlets are not recommended for commercial dishmachines; ADS recommends that a single-rack machine be installed with the wire connection (hard-wired) directly from the circuit breaker. All high temp and conveyor equipment must be hard wired. If a plug and socket are used to provide electrical power to a dishmachine in a commercial kitchen, then according to electrical code it must be a GFCI, but not all GFCIs are the same. They must be rated for the Amp draw for the designed circuit.

For Reference: The NEC Article 210.8 regarding GFCI Protection (B) Other Than Dwelling Units (2) Commercial and Institutional Kitchens. All 15 and 20A, 125V receptacles installed in kitchens, even those that do not supply the countertop surface, must be GFCI protected.



WARNING

The chemical feeders and controls contained in this publication require the following precautions:

READ Manufacturer's Manual before Using this Product. For your safety read and observe all warnings in these instructions. While performing installation of parts described in this booklet, wear approved Personal Protective Equipment, including chemically resistant gloves and Safety Eye-Wear.

CHEMICALS: There are potentially hazardous situations when working with industrial cleaning chemicals for dishmachines. See chemical manufacturer's safe practices and SDS or MSDS sheets for handling and installing chemicals and supply containers.

Chemicals can damage or corrode plumbing and stainless parts of the dishmachine. Do not run chemical lines over controls or plumbing. Always secure chemical lines and check regularly for leaks. **If not properly handled, chemicals can cause serious bodily injury. In the event of chemical contact to skin or eyes; wash immediately with fresh water and seek medical attention.**

DE-LIMING THE MACHINE: Because of potential hazards resulting from the combination of chlorine with acid solution, only authorized trained individuals must be allowed to de-lime a commercial dishmachine.

CONTAINERS: The ADS chemical delivery system is designed for 5 gallon pails of industrial low-energy chemical products. Always use chemical resistant safety gloves and safety goggles (indirect-vented or non-vented) when changing chemical buckets. Immediately report spills and refer to your chemical suppliers SDS safety data sheet or MSDS material safety data sheet for information if chemical comes in contact with skin or eyes.

Any modifications to the chemical delivery system for smaller containers must include Closed Loop Chemical Containers (spill proof bottles) in a secured racking system. It is the responsibility of the user of the machine to purchase chemicals in spill proof containers. **FAILURE CAN RESULT IN SERIOUS INJURY.** Never place chemicals in open containers or containers that can be easily tipped over when moving or changing product. Failure to do so will void your ADS warranty.

Chemical supplies must be kept in closed delivery containers to avoid spills or contamination. Do not place chemical solutions in open containers or containers that can be easily tipped over in moving or changing.

Do not open the doors while the machine is in operation. Doing so could result in serious bodily injury from spraying hot water and chemicals.



The door lever arm parts in this publication are installed under spring tension and caution is needed whenever parts are changed. Wear safety glasses when working on the doors and lever. Care should be taken when moving, installing, or replacing any door lever arm parts. Use the ADS lever arm tool to unload the door spring during replacement or adjustment. The spring tension suddenly released can result in pinch or blunt trauma, and puncture wounds. If a wound occurs from the release of spring tension, wash the wound area immediately because of the soils that can accumulate on the metal parts and seek medical attention.

NOTICE

BEFORE YOU BEGIN: American Dish Service provides this information as a service to our customers. **Keep all instructions for future reference.** ADS reserves the right to alter or update this information at any time. Should you desire to make sure that you have the most up-to-date information, we would direct you to the appropriate document on our web site: www.americandish.com. **It is your obligation as the customer to ensure that the replacement parts for the machine are installed safely and properly, and when completed, the machine is left in proper and safe working order.** Electrical, Plumbing, and Chemical hookup must be performed by a qualified professional who will ensure that the equipment is installed in accordance with all applicable Codes, Ordinances, and Safety requirements. Failure to follow the installation instructions will void the warranty. **ADS assumes no liability or control over the installation of the equipment or replacement parts. Product failure due to improper installation is not covered under the ADS Warranty.**

Plumbing Parts:

When working on the water inlet manifold, first relieve the water line pressure by turning off the water supply to the machine then energize the machine's fill valve. By doing this the manifold will empty of water. Turn off the electrical power and lock out/tag out the machine. It will then be safe to open the plumbing inlet manifold.

TANKLESS WATER HEATERS have shown to be problematic for commercial dishmachines. It has been the experience of ADS that tankless supply systems require multiple units plumbed in sequence with a recirculation loop to achieve proper pressure and temperature.

Check with the tankless water heater manufacturer, they may recommend a storage tank to guarantee proper flow and line pressure to the machine. Failure to provide adequate water quantity, pressure and temperature to the machine will cause the machine to function improperly and is not the responsibility of ADS. Improperly installing ADS equipment or parts in this manner could void the warranty. All costs associated with providing an adequate water supply to the machine is the sole responsibility of the user.

Drain replacement parts should not be reduced in size, all drain lines should remain the same size as it exits the dishmachine or larger. If you have questions, call 800-922-2178 or visit our website at www.AmericanDish.com.

Model AWS, AWS-H

PARTS MANUAL

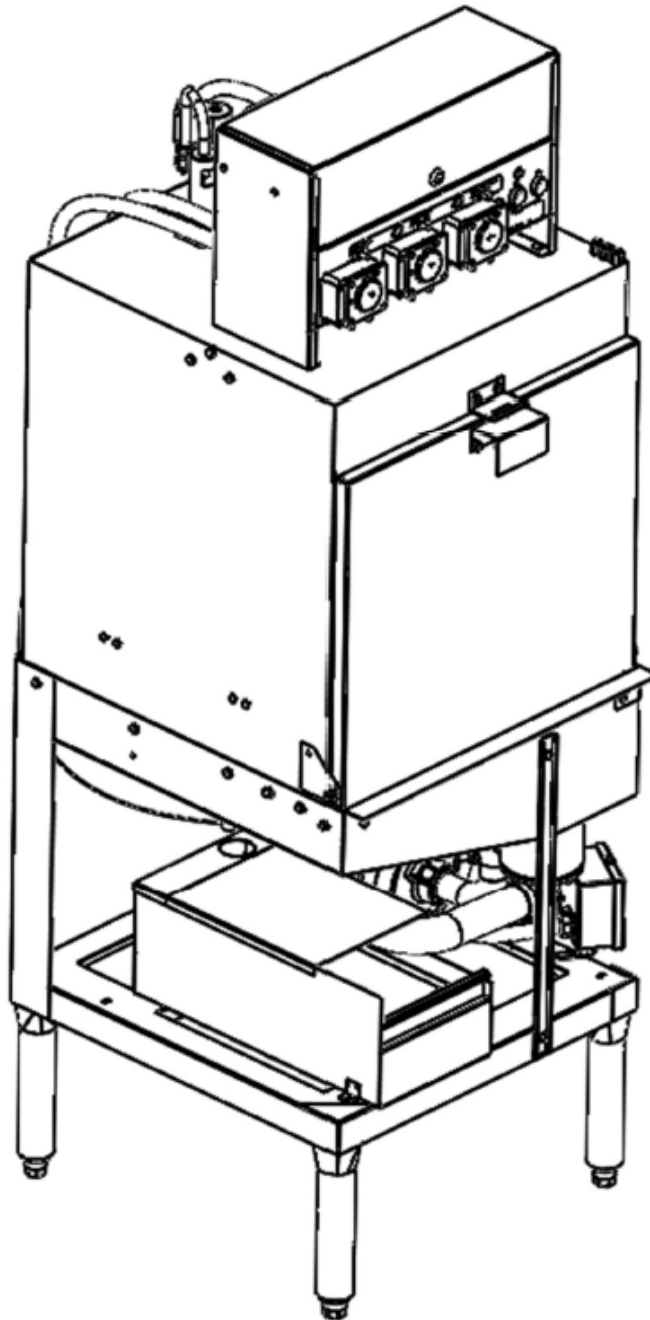

Table of Contents

AWS, AWS-H

Cabinet Assembly	6
Cabinet Bill of Materials	7
Door Fastener & Handle Assembly	8
Door Fastener & Handle Bill of Materials.	9
Door Assembly & Installation Tool	10
Door Assembly & Installation Tool Bill of Materials	11
Pump Assembly	12
Pump Assembly Bill of Materials	13
Spray Arm System.	14
Spray System Bill of Materials	15
Control Box (Image 1).	16
Control Box Bill of Materials.	17
Control Box (Image 2)	18
Control Box Bill of Materials (Cont.)	19
Chemical Pump Assembly - AF, AWS, AFC-ES, ASQ.	20
Chemical Pump Assembly Bill of Materials.	21
Fresh Water Plumbing Assembly	22
Fresh Water Plumbing Bill of Materials.	23
Drain Sump Assembly	24
Drain Sump Bill of Materials	25
Optional Overshelf and Undershelf	26
Optional Overshelf and Undershelf Bill of Materials	27
Heater Option Additional Components	28
Heater Option Additional Components Bill of Materials	29
Heater Option Additional Components (Cont.)	30
Heater Option Additional Components Bill of Materials	31

Cabinet Assembly

AWS, AWS-H

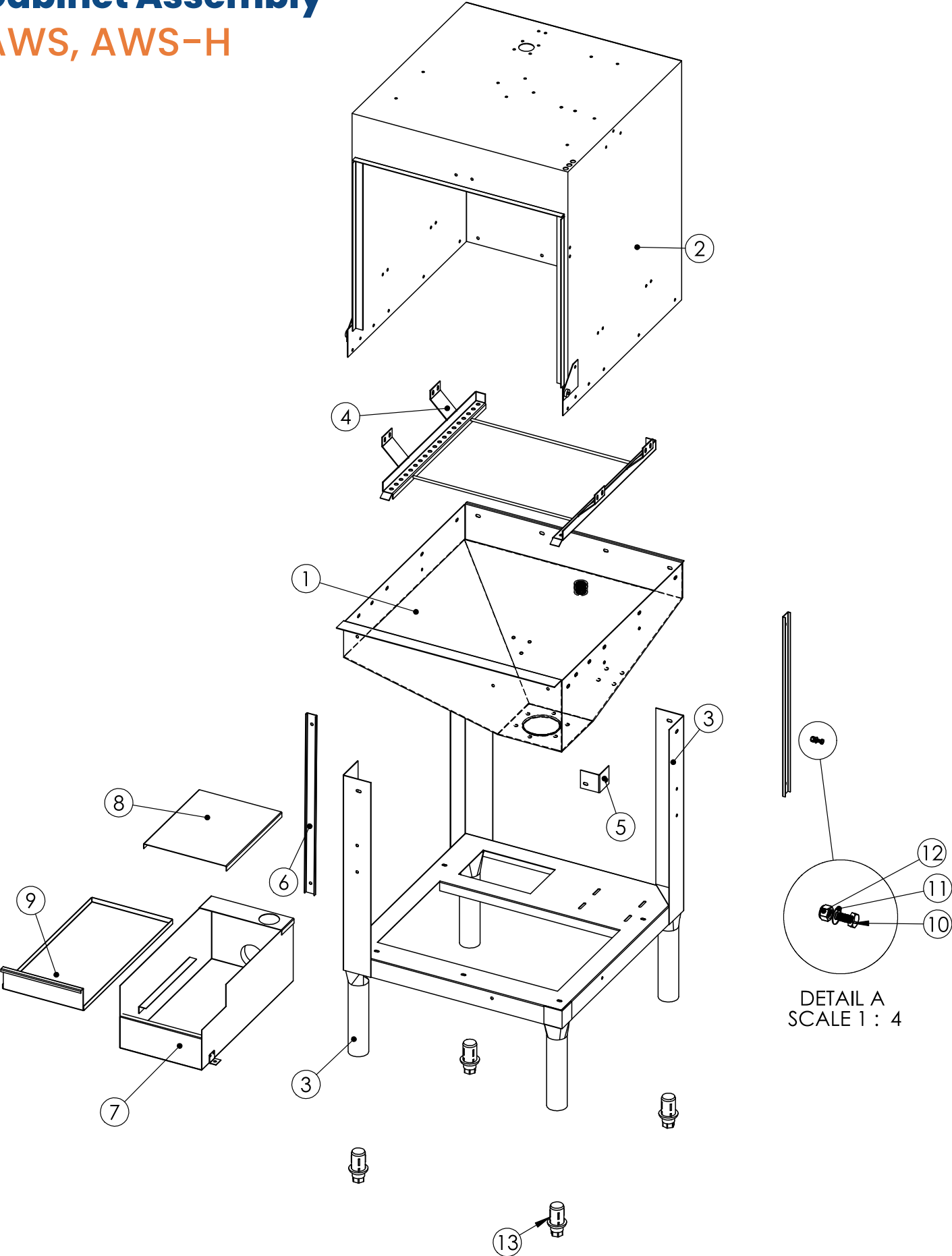

Cabinet Assembly

Bill of Materials

Item No.	Part Number	QTY.	Description
1	085-6230	1	Pan, AWS
2	085-6242	1	Hood, AWS (-H)
3	085-6243	1	Frame, AWS (-H)
4	085-6248	1	Tray Track, AWS(-H)
5	086-6498	1	Pan Corner Support Bracket, AWS and AWS-H
6	087-6599	2	Sump Support, AWS
7	089-9046	1	Scrap Trap, Rear Exit, AWS (-H) Box Only
8	089-9047	1	Scrap Trap Lid, AWS
9	089-9061	1	Tray, Scrap Accumulator AF/AFC-ES, AWS(-H)
10	098-1423	12	Bolt, 1/4"-20 x 1/2", HH
11	098-2404	18	Washer, 1/4" SS Flat (Large)
12	098-2507	30	Nut Lock, 1/4"-20 w/ Nylon Insert
13	099-1003	4	Bullet Foot, 1-1/4"

Door Fastener & Handle Assembly

AWS, AWS-H

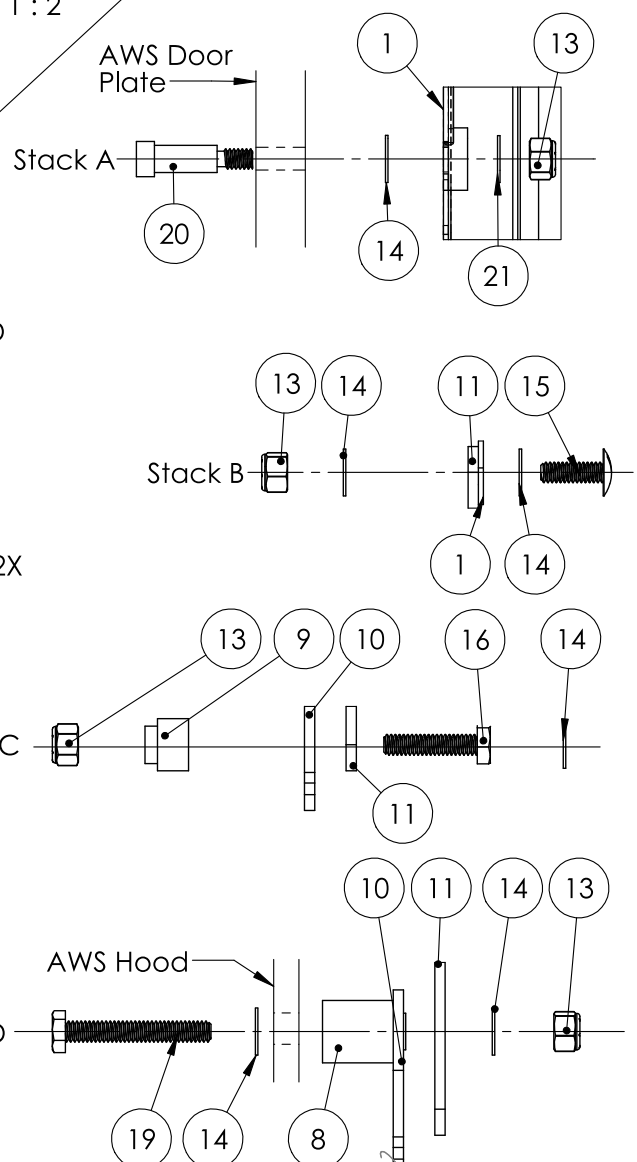
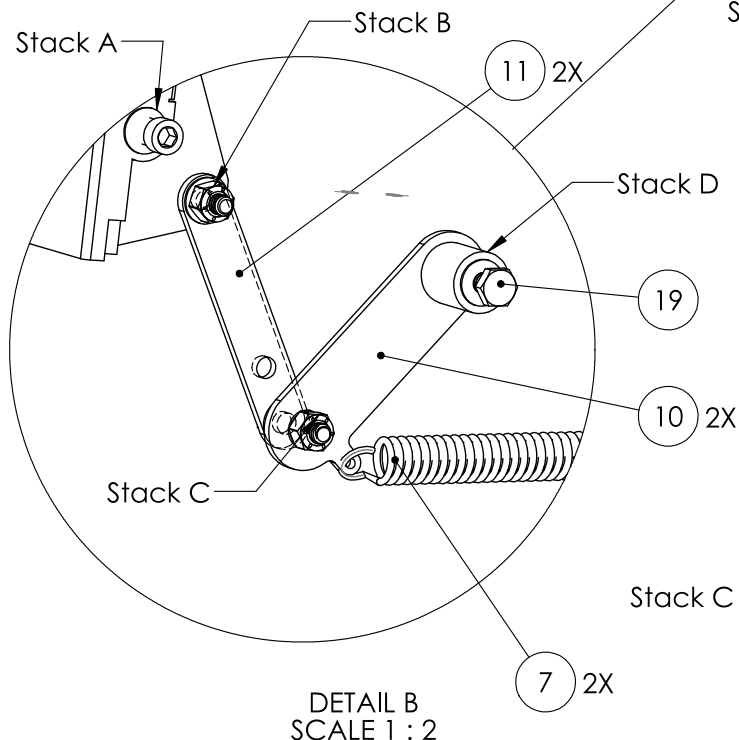
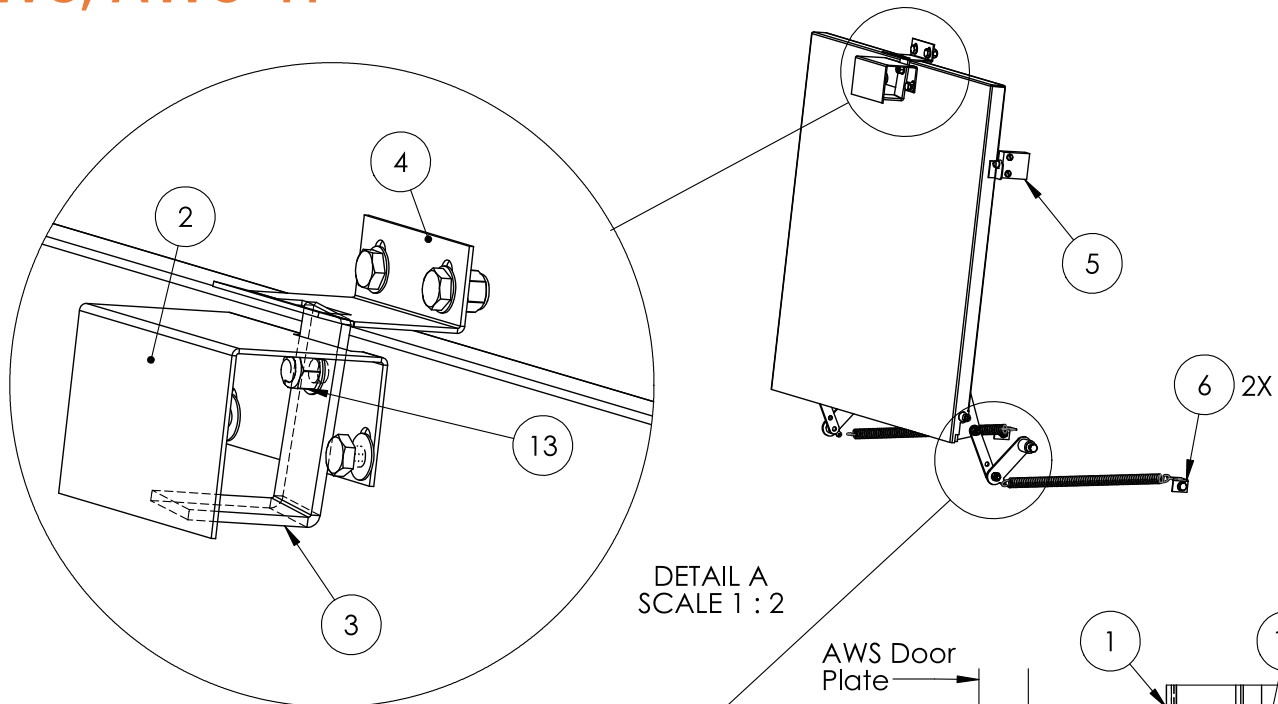

Door Fastener & Handle Assembly

Bill of Materials

Ref. No.	Part No.	No. Req.	Description
1	085-6244	1	Door, AWS(-H)
2	085-6247	1	Handle, Door AWS(-H)
3	086-6487	1	Door Latch Lever, AWS (-H)
4	086-6488	1	Door Latching Plate, AWS
5	091-3070	1	Switch, Door Cut-Off, ET-AF R
6	086-6430	2	Bracket, Door Spring Mounting, ET-AF
7	098-3015	2	AWS Door Springs
8	084-6117	2	Door Link Bushing, AWS/AWS-H
9	084-6118	2	Door Link Spacer Bushing, AWS/AWS-H
10	086-6484	2	Door Spring Link, AWS
11	086-6485	2	Door Link, AWS
12	098-1423	6	Bolt, 1/4-20 x 1/2" HH
13	098-2507	15	Nut, Lock, 1/4-20 w/ Nylon Insert
14	098-2404	18	Washer, 1/4" SS Flat (Large)
15	098-1416	2	Screw, 1/4-20 x 3/4" Truss Head
16	098-1428	2	Bolt, 1/4-20 x 1-1/8" Large HH, SS
17	098-2301	2	Nut, Lock, 10-32
18	098-1305	2	Screw, 10-32 x 1-1/2" RH
19	098-1432	2	Bolt, 1/4-20 x 1-3/4" HH
20	098-1417	2	Screw, Socket Shoulder 1/4-20 x 5/16" x 1/2"
21	098-2503	2	Washer, 5/16 Copper
22	086-6497	1	Spring Installation Hook, AWS/AWS-H

Door Assembly & Installation Tool

AWS, AWS-H

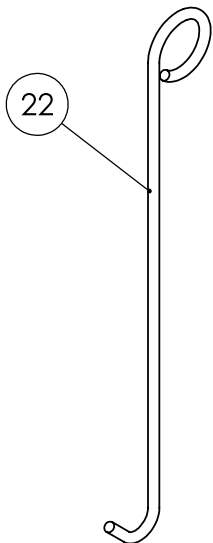
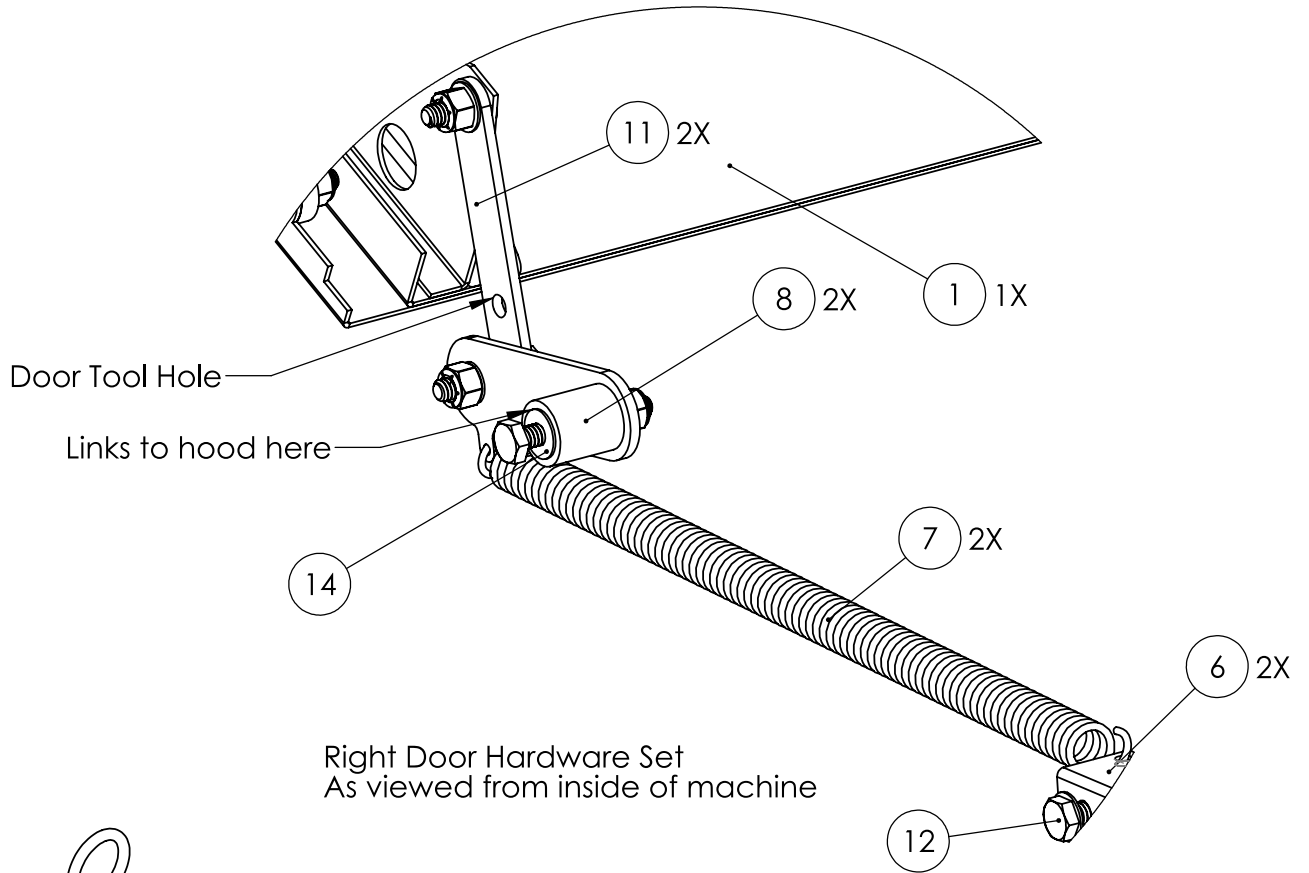

Use of Spring Installation Hook

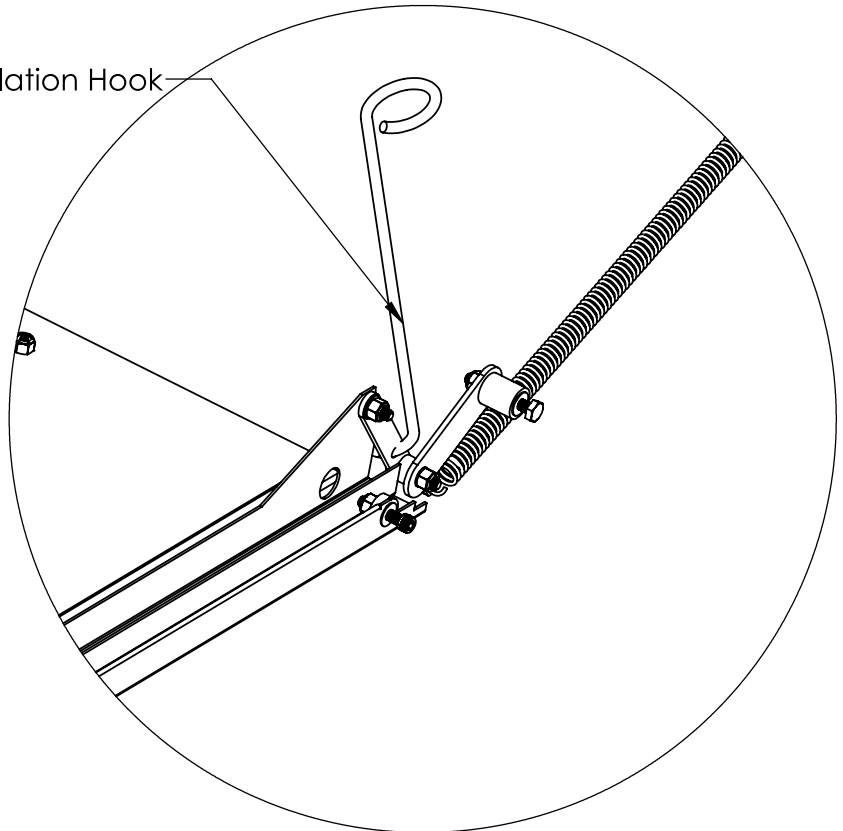

086-6497
Spring Installation Hook, AWS/AWS-H

Door Assembly & Installation Tool

Bill of Materials

Ref. No.	Part No.	No. Req.	Description
1	085-6244	1	Door, AWS(-H)
2	085-6247	1	Handle, Door AWS(-H)
3	086-6487	1	Door Latch Lever, AWS (-H)
4	086-6488	1	Door Latching Plate, AWS
5	091-3070	1	Switch, Door Cut-Off, ET-AF R
6	086-6430	2	Bracket, Door Spring Mounting, ET-AF
7	098-3015	2	AWS Door Springs
8	084-6117	2	Door Link Bushing, AWS/AWS-H
9	084-6118	2	Door Link Spacer Bushing, AWS/AWS-H
10	086-6484	2	Door Spring Link, AWS
11	086-6485	2	Door Link, AWS
12	098-1423	6	Bolt, 1/4-20 x 1/2" HH
13	098-2507	15	Nut, Lock, 1/4-20 w/ Nylon Insert
14	098-2404	18	Washer, 1/4" SS Flat (Large)
15	098-1416	2	Screw, 1/4-20 x 3/4" Truss Head
16	098-1428	2	Bolt, 1/4-20 x 1-1/8" Large HH, SS
17	098-2301	2	Nut, Lock, 10-32
18	098-1305	2	Screw, 10-32 x 1-1/2" RH
19	098-1432	2	Bolt, 1/4-20 x 1-3/4" HH
20	098-1417	2	Screw, Socket Shoulder 1/4-20 x 5/16" x 1/2"
21	098-2503	2	Washer, 5/16 Copper
22	086-6497	1	Spring Installation Hook, AWS/AWS-H

AWS Pump Assembly

AWS, AWS-H

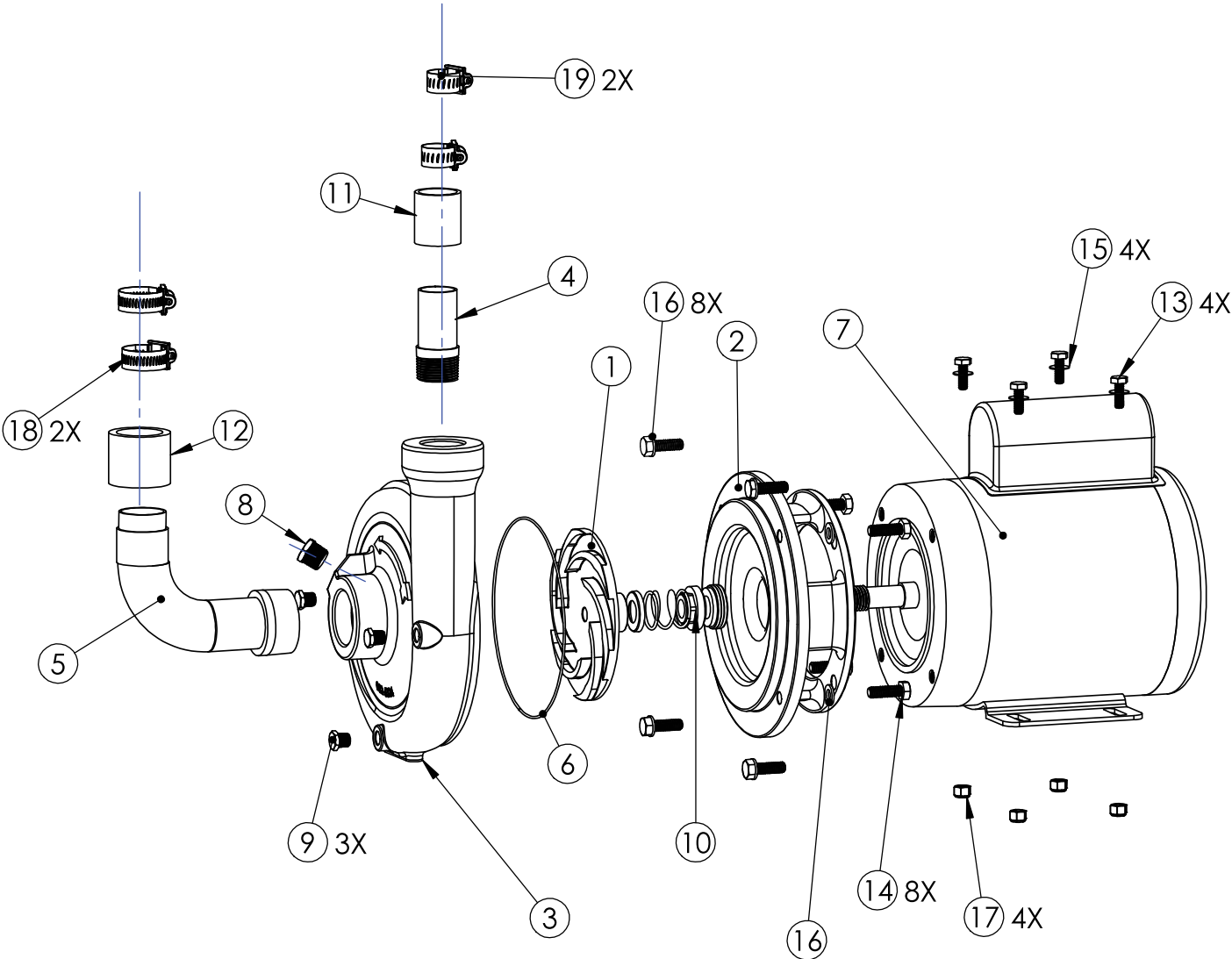

AWS Pump Assembly

Bill of Materials

Ref. No.	Part No.	No. Req.	Description
1	082-6312	1	Impeller, S/S Open, ES Series
2	082-6323	1	Housing, Water Pump SS "Rear" (1-1/2 HP Pump)
3	082-6324	1	Cover, Water Pump SS
4	085-6198	1	Tube, Pump Discharge 3DS, AFB, & AFB-C
5	085-6340	1	Suction Tube Weldment, AWS/AWS-H
6	089-6309	1	Gasket, O-Ring, Water Pump, ES Series, L-Series & Pre-wash
7	091-1001	1	Motor, Wash Pump 1-1/2 HP N
8	092-1144	1	Plug, Pipe 3/8", MPT, SS, Hex head
9	092-1145	3	Plug, Pipe 1/8", MPT, SS, Hex head
10	092-2001	1	Seal, Wash Pump (DWMS) R
11	093-1048	1	Sleeve Only, Discharge Tube (Part of 093-1040) C
12	093-1049	1	Sleeve Only, Suction Tube (Part of 093-1039) C
13	098-1426	4	Bolt, 1/4-20 x 3/4" HH
14	098-1516	8	Bolt, 5/16-18 x 1" HH
15	098-2404	4	Washer, 1/4" SS Flat (Large)
16	098-2503	4	Washer, 5/16 Copper
17	098-2507	4	Nut, Lock, 1/4-20 w/ Nylon Insert
18	098-9024	2	Clamp, Hose - Screw Type 3/4"
19	098-9037	2	Clamp, Discharge Tube Sleeve, Model 3DS, ES, 5AG-S, 5AG-ES

Spray Arm System

AWS, AWS-H

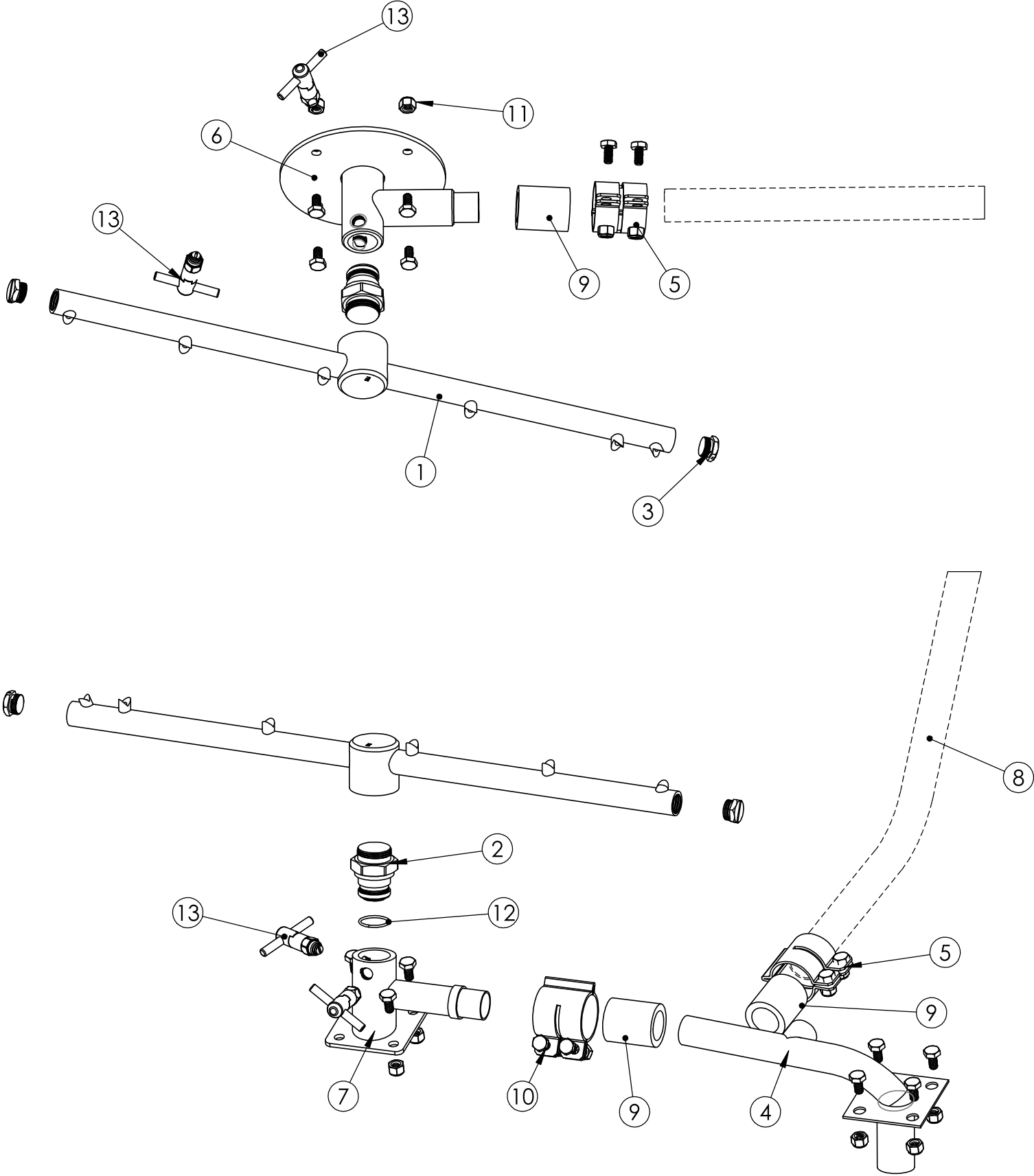

Spray Arm System

Bill of Materials

Ref. No.	Part No.	No. Req.	Description
1	085-6661	2	Spray Arm Weldment, 5AGES
2	081-6217	2	Spray Arm Bearing With O-Ring R
3	084-6211	4	Spray Arm End Plug, SS
4	085-6342	1	Y Pipe Weldment, AWS
5	085-6407	3	Clamp, Inside Manifold, SS, Welded Clamp (Assy See 081-6501)
6	085-6626	1	Base, Spray, Upper SS, 3D-S, ES, 5AG-S, & AFB (Bayonet Type)
7	085-6646	1	Spray Base Weldment, Lower, AWS
8	087-6276	1	Upper Spray Manifold, AWS
9	093-1047	3	Sleeve Only, Inside Manifold Tube (Part of 093-1041) C
10	098-1423	17	Bolt, 1/4-20 x 1/2" HH
11	098-2507	17	Nut, Lock, 1/4-20 w/ Nylon Insert
12	089-6310	2	O-Ring, Spray Arm Bearing
13	099-1028	4	Bayonet, Spray Base Pin N

Control Box (Image 1)

AWS, AWS-H

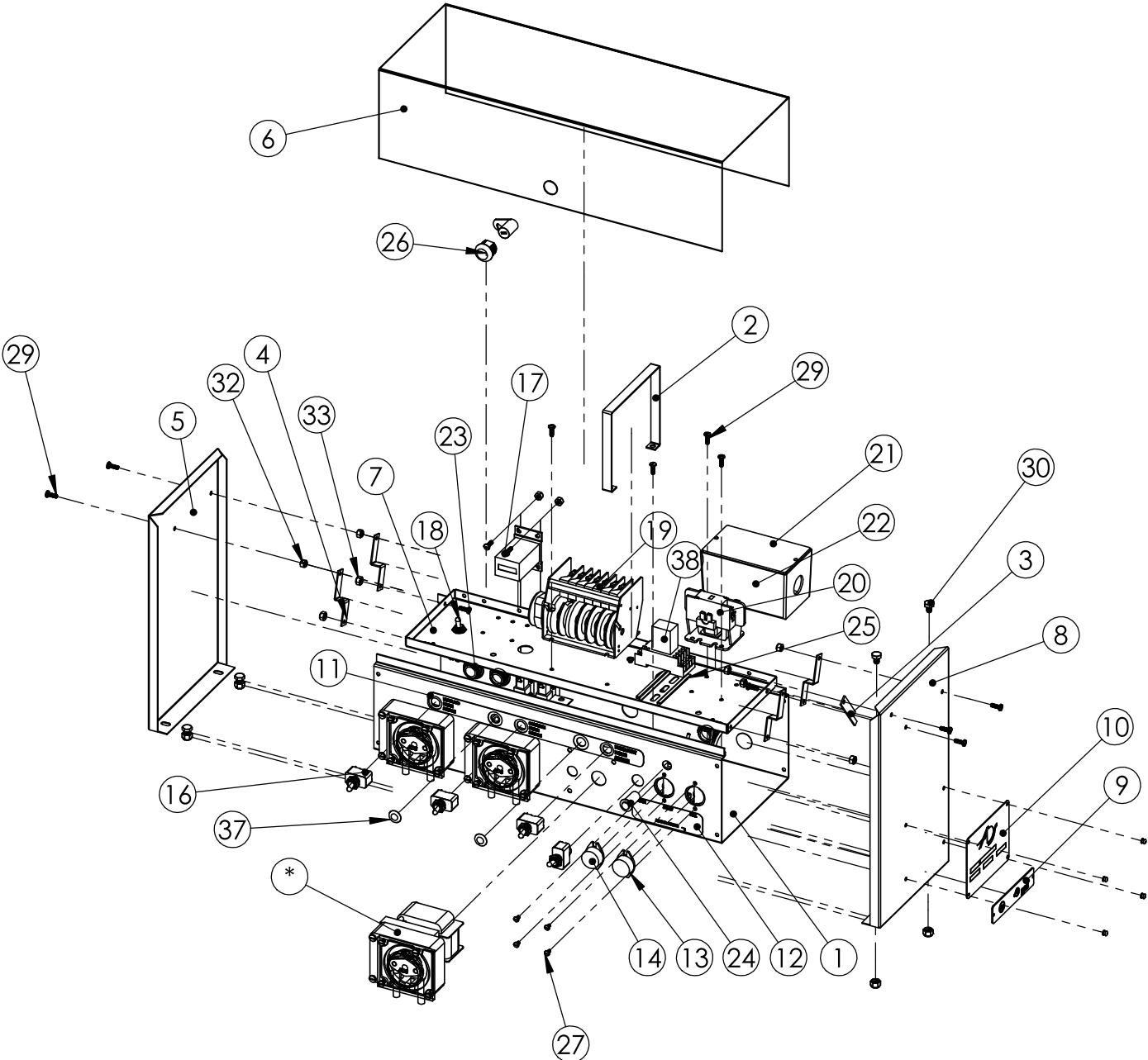

Control Box

Bill of Materials

Ref. No.	Part No.	No. Req.	Description
1	085-6344	1	Control Box Bottom, AWS (-H)
2	086-6317	1	Handle, Control Box Upper Shelf
3	086-6676	1	Latch, Control Box Shelf Safety
4	086-6678	4	Hinge, Control Box Shelf
5	087-6431	1	Control Box End Panel, Left Side
6	087-6433	1	Cover, Control Box, ES, 3DS, 5AG-S, 5CD & L-3DW-S
7	087-6435	1	Control Box, Upper Shelf, 3DS, 5AG-S, AF-ES, 5AG-ES & 5CD
8	087-6447	1	Control Box RH Side, AWS
9	089-0050	1	NSF, cUL, UL Plate
10	089-0077	1	ADS Name Plate, Partially Pre-Printed
11	089-9321	1	Decal, Prime Switches, 12" x 1-1/4" (Tackle Box)
12	089-9497	1	Decal AWS, Drain, Start, & Fill
13	091-3001	1	Switch, Black Fill R
14	091-3002	1	Switch, Red Start R
15	091-3008	1	Switch, Master (Main Power) R
16	091-3009	4	Switch, Prime & Drain, Momentary R
17	091-3049	1	Counter, Electric
18	091-3060	1	Switch, Wash Extender, Delime Switch
19	091-3073	1	Timer (7 Cam), 90 Second L Series, AF AFC-ES
20	091-3083	1	Contact, 40 Amp R
21	091-4004	1	Cover, Junction, AF, 3D, ES, 5AG-S, 5CD, ADC-44 & 66
22	091-4016	1	Box, Junction, 5AG-S, 5AG-ES & 5CD
23	091-4141	3	Conduit Fitting, 1/2", Straight
24	091-7006	1	Light, Indicator, 110 Volt
25	091-9105	1	Din Rail, 3-3/4"
26	096-1002	1	Lock, Control Box, w/ Keys (251)
27	098-1102	4	Screw, 6-32 x 1/4" RH, Slotted
28	098-1104	9	Screw, 6-32 x 1/2" RH
29	098-1204	16	Screw, 8-32 x 1/2" RH Slotted
30	098-1423	4	Bolt, 1/4-20 x 1/2" HH
31	098-2106	4	Locknut 6-32 SS
32	098-2201	11	Nut, Lock, 8-32 Hex w/ Nylon Insert
33	098-2301	4	Nut, Lock, 10-32
34	098-2507	4	Nut, Lock, 1/4-20 w/ Nylon Insert

Control Box (Image 2)

AWS, AWS-H

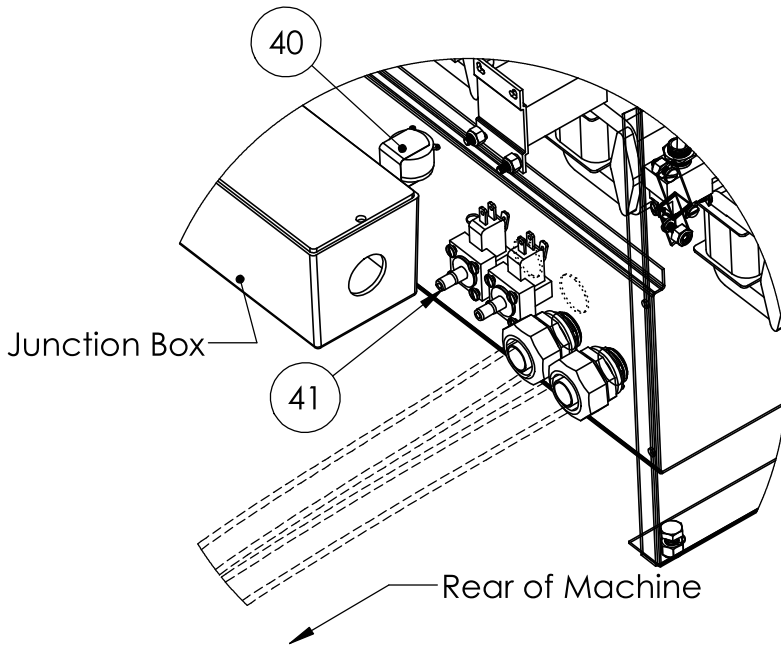

Vacuum Switch and Buzzer Locations

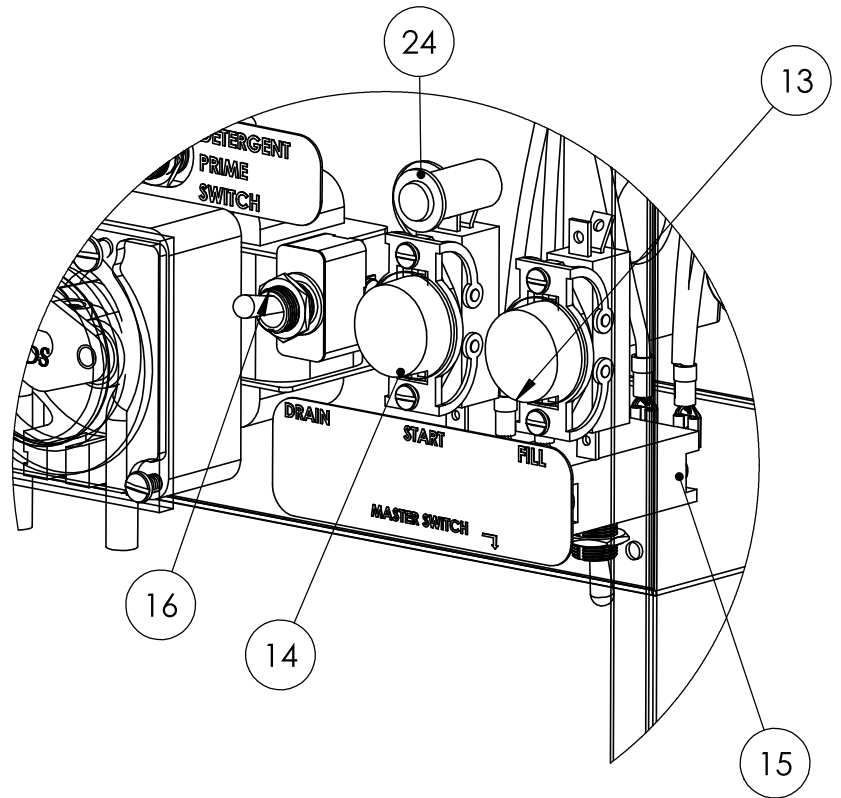

Start and Fill Button Locations

Control Box (Cont.)

Bill of Materials

Ref. No.	Part No.	No. Req.	Description
35	098-9011	4	Rivet, 1/8" Closed End Pop
36	098-9020	3	Plug, 7/8" Pipe (Plastic)
37	098-9022	2	Plug, 3/8" Pipe (fits 1/2" Hole)
38	291-3005	1	Relay, Cube, DPDT, 110 Volt, ADC44/66, N
39	291-3009	1	Socket, Relay, Din Rail N
40	037-2103	1, Opt.	Buzzer, Chemical Alarm (for 031-0326)
41	091-3080	2, Opt.	Switch, Vac., Low Level Alarm
N/S	091-5040	1	Wire Harness, AWS
N/S	093-1061PCS	1	Tubing, Chemical Line, 1/4" Blue Vinyl (9 ft Precut)
N/S	093-1062PCS	1	Tubing, Chemical Line, 1/4" Green Vinyl (9 ft Precut)
N/S	093-1063PCS	1	Tubing, Chemical Line, 1/4" Red Vinyl (9 ft Precut)
N/S	093-1061PCL	1	Tubing, Chemical Line, 1/4" Blue Vinyl (15 ft Precut)
N/S	093-1062PCL	1	Tubing, Chemical Line, 1/4" Green Vinyl (15 ft Precut)
N/S	093-1063PCL	1	Tubing, Chemical Line, 1/4" Red Vinyl (15 ft Precut)
N/S	091-4135	3	Fitting, Chem. Discharge R
N/S	091-4157	2	Nut, Threaded Red, Tube Stiffener
N/S	091-4158	2	Nut, Threaded Blue, Tube Stiffener
N/S	091-4159	2	Nut, Threaded Red, Tube Stiffener
	091-5156	25"	1/2" Conduit, 25" Long, Control Box to Fresh Water Fill Solenoid
N/S	091-5156	25in	1/2" Conduit, 25" Long, Control Box to Fresh Water Fill Solenoid
N/S	091-5156	80in	1/2" Conduit, 80" Long, Control Box to Drain Box
N/S	091-5156	83in	1/2" Conduit, 83" Long, Control Box to Wash Pump
	089-9201	1	Decal, Wiring Diagram, AF, AFB, AFC, 3-D, L & ES Series
N/S	089-9201	1	Decal, Wiring Diagram, AF, AFB, AFC, 3-D, L & ES Seri
N/S	089-9205	1	Decal, Cleaning Instruction (Inside)
N/S	089-9209	1	Decal, Conn. To Power Source 20 amp
N/S	089-9226	1	Decal, Timer Cam
N/S	089-9227	1	Decal, Timer Cam Adjustment, DWMs
N/S	089-9257	1	Decal, Delimiting
N/S	089-9308	1	Decal, Water Level
*			*Chemical Pump Assembly Shown on Next Page

Chemical Pump Assembly - AF, AWS, AFC-ES, ASQ AWS, AWS-H

Complete Pump 064-0032

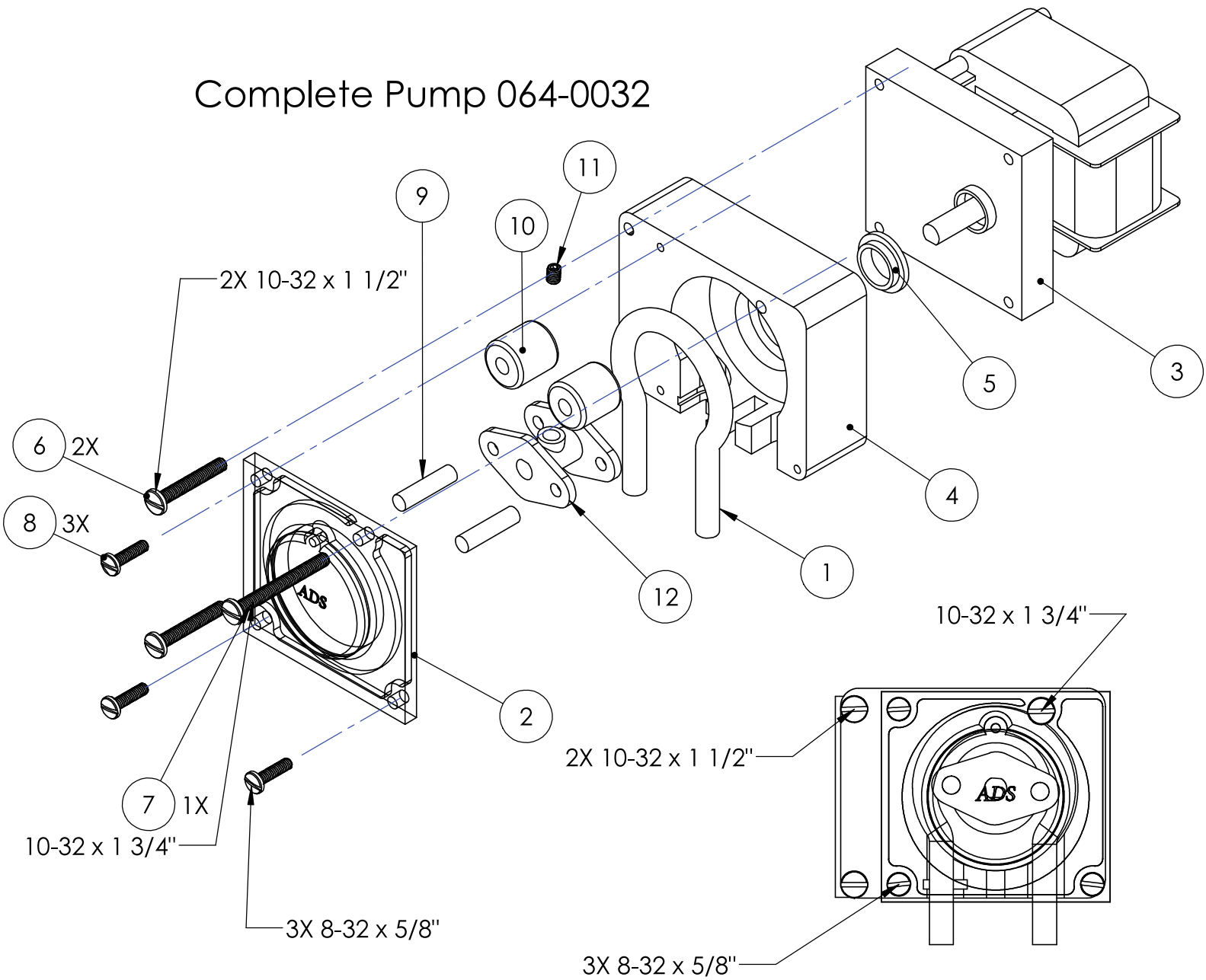

Chemical Pump Assembly

Bill of Materials

Ref. No.	Part No.	No. Req.	Description
1	093-1064	1	Tube, Squeeze, Lined Norprene "Cream"
2	083-6707	1	Cover, Chem. Pump (External) R
3	091-1023	1	Motor, Chemical Pump, AF AFC-ES & ASQ (25RPM)
4	083-6703	1	Housing, Chem. Pump (External) R
5	083-6708	1	Bushing, Chem. Pump (External) R
6	098-1305	2	Screw, 10-32 x 1-1/2" RH
7	098-1321	1	10-32 x 1-3/4" RH Slotted
8	098-1205	3	Screw, 8-32 5/8" RH Slotted
9	083-6706	2	Pump Pin, Chemical, AFC-3D SS
10	083-6705	2	Roller (Rotor), Chemical Pump, External Mount R
11	098-1322	1	Screw, 10-32 x 1/4" Socket Head Set
12	083-6704	1	Pump Rotor, Chemical, AF/AFC-3D 'H' Frame R

Fresh Water Plumbing Assembly

AWS, AWS-H

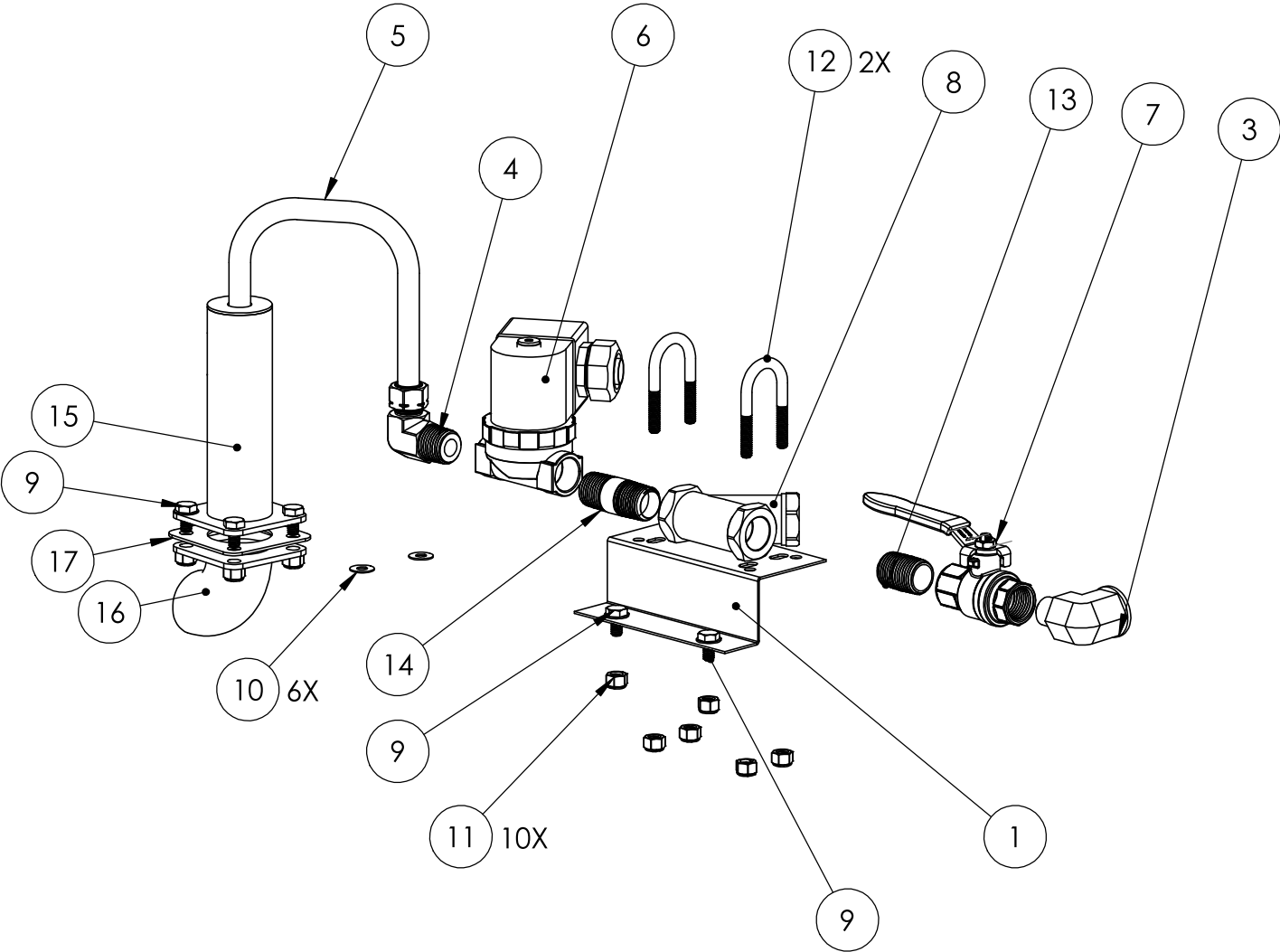

Fresh Water Plumbing Assembly

Bill of Materials

Ref. No.	Part No.	No. Req.	Description
1	086-6537	1	Bracket, "Mounting", Fresh Water Plumb., 3D, L & ES Series
2	091-4141	1	Conduit Fitting, 1/2", Straight
3	092-1006	1	Fitting, Plumb. Street "L" 1/2", "LF"
4	092-1062	1	Fitting, Plumb. 1/2" Comp. x 1/2" MPT, 90* Elbow "LF"
5	092-3118	1	Tube, Fresh Water Supp., 3DS & ES, Air Gap
6	092-5015	1	Valve, Water Solenoid 1/2" G R
7	092-5054	1	Valve, Ball 1/2", "LF"
8	092-9001	1	Line Strainer, 1/2" Y Type (standard Size For ADS), "LF" R
9	098-1423	6	Bolt, 1/4-20 x 1/2" HH
10	098-2404	6	Washer, 1/4" SS Flat (Large)
11	098-2507	10	Nut, Lock, 1/4-20 w/ Nylon Insert
12	098-9027	2	Bolt, 1/4" U (3D, ES, L-Series, ADC-44, & ADC-66)
13	292-3003	1	Nipple, 1/2" x Close, SS N
14	292-3014	1	Nipple, 1/2" x 2" Stainless N
15	385-6121	1	Air Gap, HT-25 & 3D-S Series
16	385-6124	1	Elbow, Air Gap Outlet Flange (Need Gasket 389-6603)
17	389-6603	1	Gasket, Air Gap Flange

Drain Sump Assembly

AWS, AWS-H

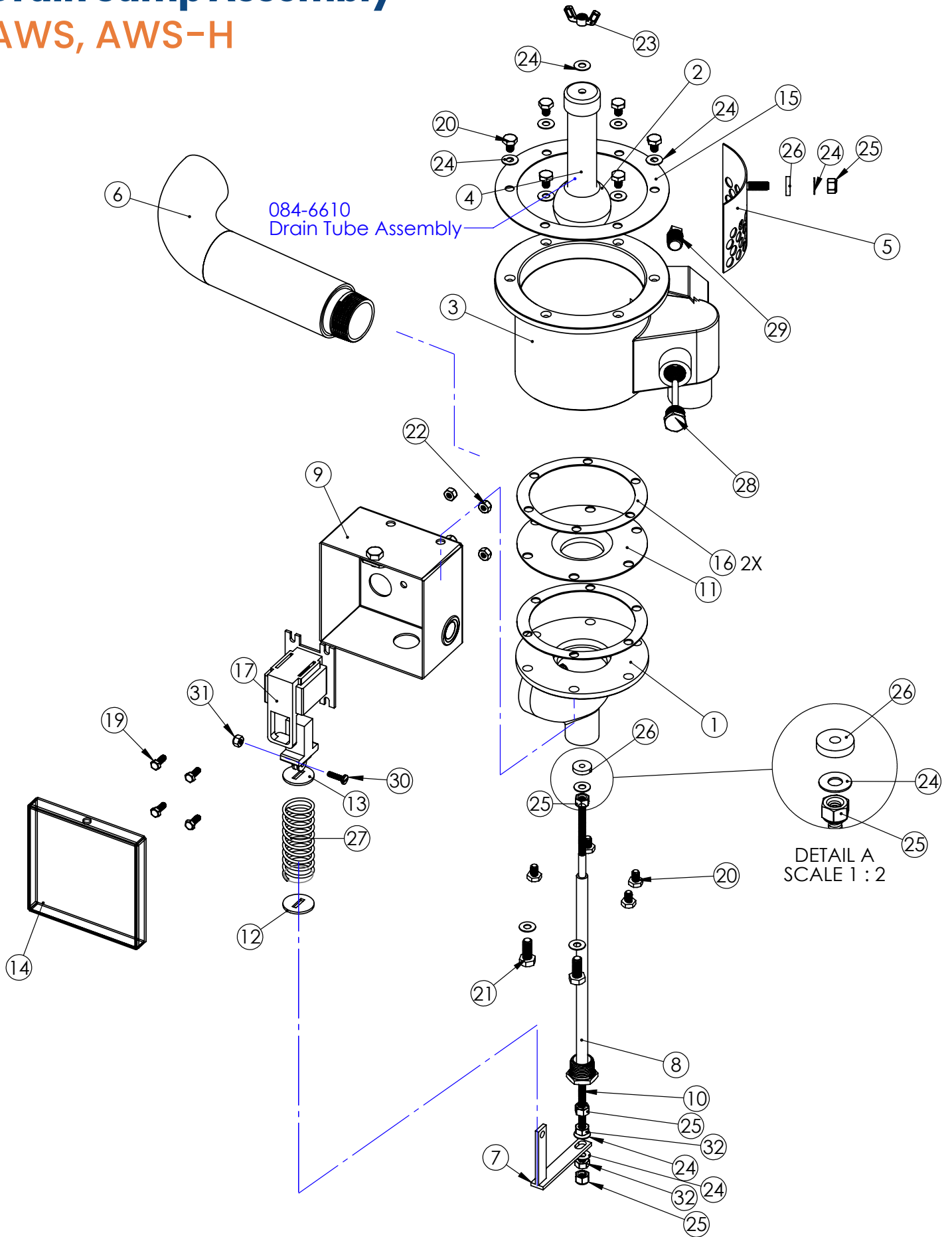

Drain Sump Assembly

Bill of Materials

Ref. No.	Part No.	No. Req.	Description
1	082-6609	1	Drain Elbow, L Series, ET-AF-M & ET-3
2	083-6601	1	Drain Ball, 1-1/2" C
3	085-6204	1	Drain Casting, w/Tail Piece, 3D-S & ES Series, 5AG-S, 5AGES
4	084-6610	1	Drain Tube, Inside Sump C
5	085-6160	1	Screen, Drain Secondary, "L" & "ES" Series
6	085-6246	1	Discharge pipe, Sump to Scrap Trap, AWS(-H)
7	085-6610	1	Link, Drain Solenoid (Inside Sump)
8	085-6611	1	Drain Shaft (Inside Sump)
9	085-6613	1	Box, Drain Solenoid, ET-AF & L Series
10	086-6307	1	Push Rod, Drain, ET-AF, L-3DW, L-3DWC, AFW,
11	086-6601	1	Drain Seat, 1-1/2"
12	086-6606	1	Washer Slotted, Small
13	086-6607	1	Washer Slotted, Large
14	086-6634	1	Cover, Drain Solenoid Box, AFW, AFWC, ET-AF
15	089-6601	1	Gasket, Drain Casting "Sump" R
16	089-6602	2	Gasket, Drain Tee & Drain Elbow
17	091-2014	1	Solenoid, Drain, 110 Volt (May 2018) R
18	091-4141	1	Conduit Fitting, 1/2", Straight
19	098-1306	4	Screw, 10-32 x 1/2" RH
20	098-1423	10	Bolt, 1/4-20 x 1/2" HH
21	098-1506	2	Bolt, 5/16-18 x 3/4" HH
22	098-2301	4	Nut, Lock, 10-32
23	098-2308	1	Nut, Wing, 1/4-20 w/ Nylon Insert
24	098-2404	13	Washer, 1/4" SS Flat (Large)
25	098-2507	3	Nut, Lock, 1/4-20 w/ Nylon Insert
26	098-9014	2	O-Ring, Drain "Flat" (Inside Sump) R
27	098-3007	1	Spring, Drain Solenoid, Inside Sump
28	299-1005	1	Gauge, Temp, Wash/Rinse Tanks & Inside Sumps, 6' Capillary R
29	092-1144	1	Plug, Pipe 3/8", MPT, SS, Hex head
30	098-1205	1	Screw, 8-32 x 5/8" RH Slotted
31	098-2201	1	Nut, Lock, 8-32 Hex w/ Nylon Insert
32	098-2401	2	Nut, 1/4-20 Hex
N/S	093-1027	1 ft	1-1/4" OD x 1" ID, Vinyl Tubing, ET
N/S	092-1061	1	Fitting, Plumb. 3/4", 45 Street Elbow "LF"
N/S	092-1112	1	Fitting, Plumb. 3/4" MPT x 1" Hose Barb, "LF"

Optional Overshelf and Undershelf

AWS, AWS-H

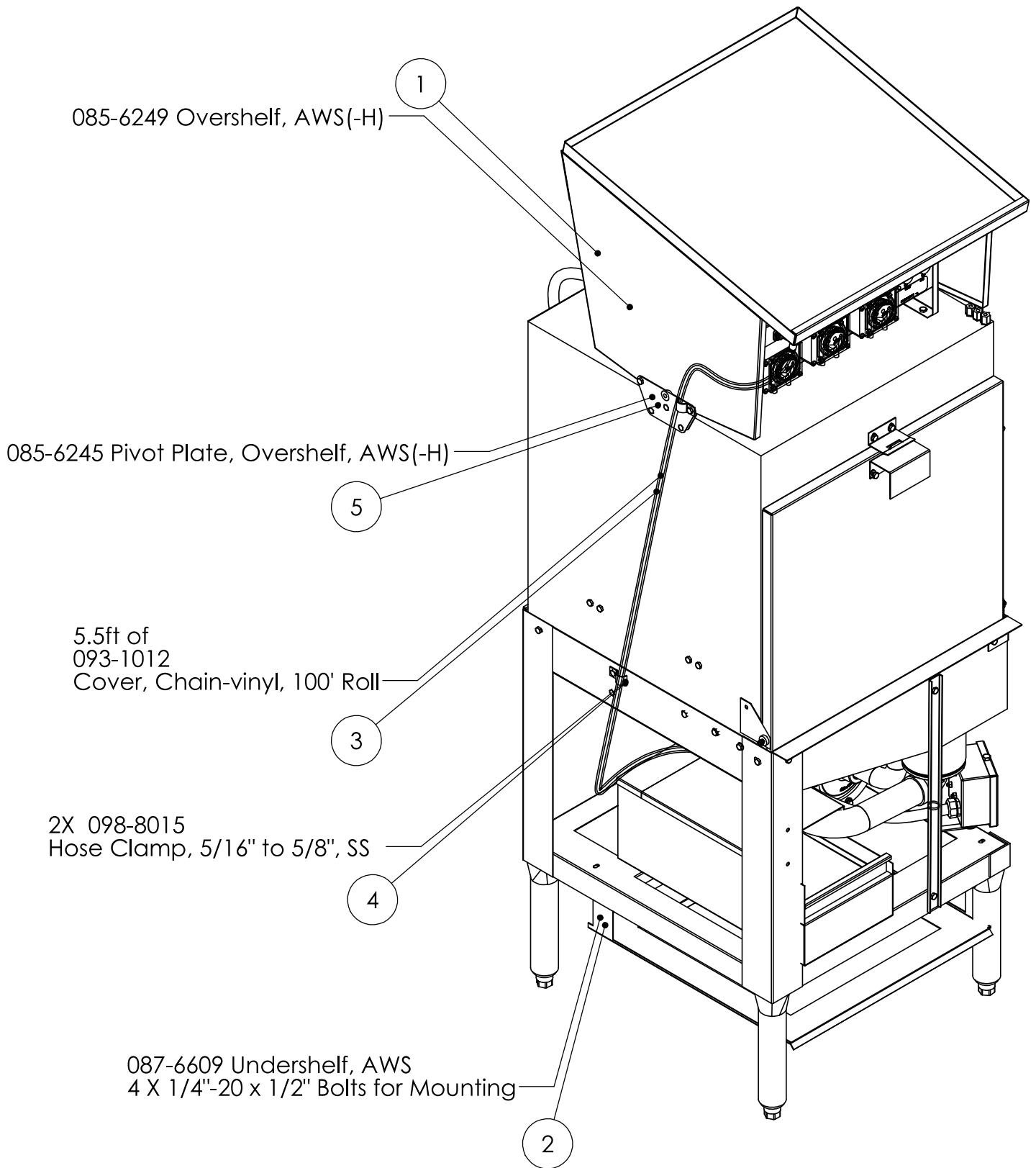

Optional Overshelf and Undershelf

Bill of Materials

Ref. No.	Part No.	No. Req.	Description
1	085-6249	1	Overshelf, AWS(-H)
2	087-6609	1	Undershelf, AWS
For Mounting Overshelf			
3	093-1012	5.6 ft	Cover, Chain-vinyl, 100' Roll
4	098-8015	2	Hose Clamp, 5/16" to 5/8", SS
5	085-6245	2	Pivot Plate, Overshelf, AWS(-H)
N/S	098-1417	2	Screw, Socket Shoulder 1/4-20 x 5/16" x 1/2"
N/S	098-2507	6	Nut, Lock, 1/4-20 w/ Nylon Insert
N/S	098-2416	6	Washer, 1/4" Flat, SS
N/S	098-1423	6	Bolt, 1/4-20 x 1/2" HH
For Mounting Undershelf			
N/S	098-1423	4	Bolt, 1/4-20 x 1/2" HH
N/S	098-2416	4	Washer, 1/4" Flat, SS
N/S	098-2507	4	Nut, Lock, 1/4-20 w/ Nylon Insert

Heater Option Additional Components

AWS, AWS-H

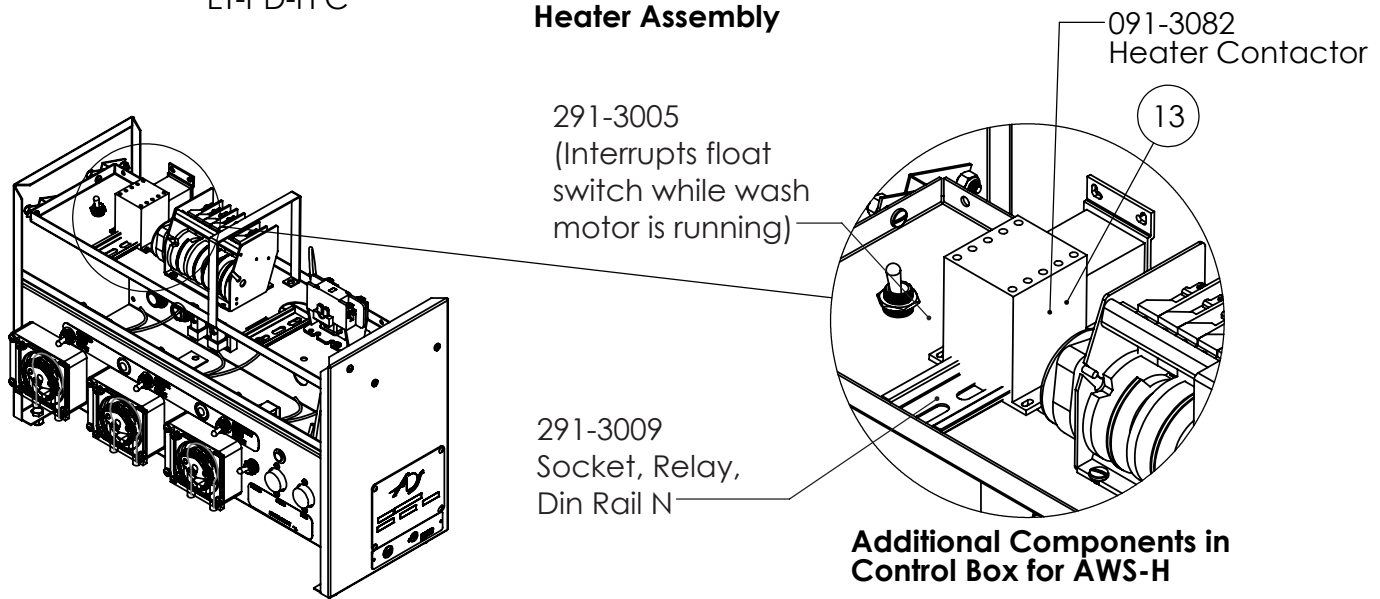
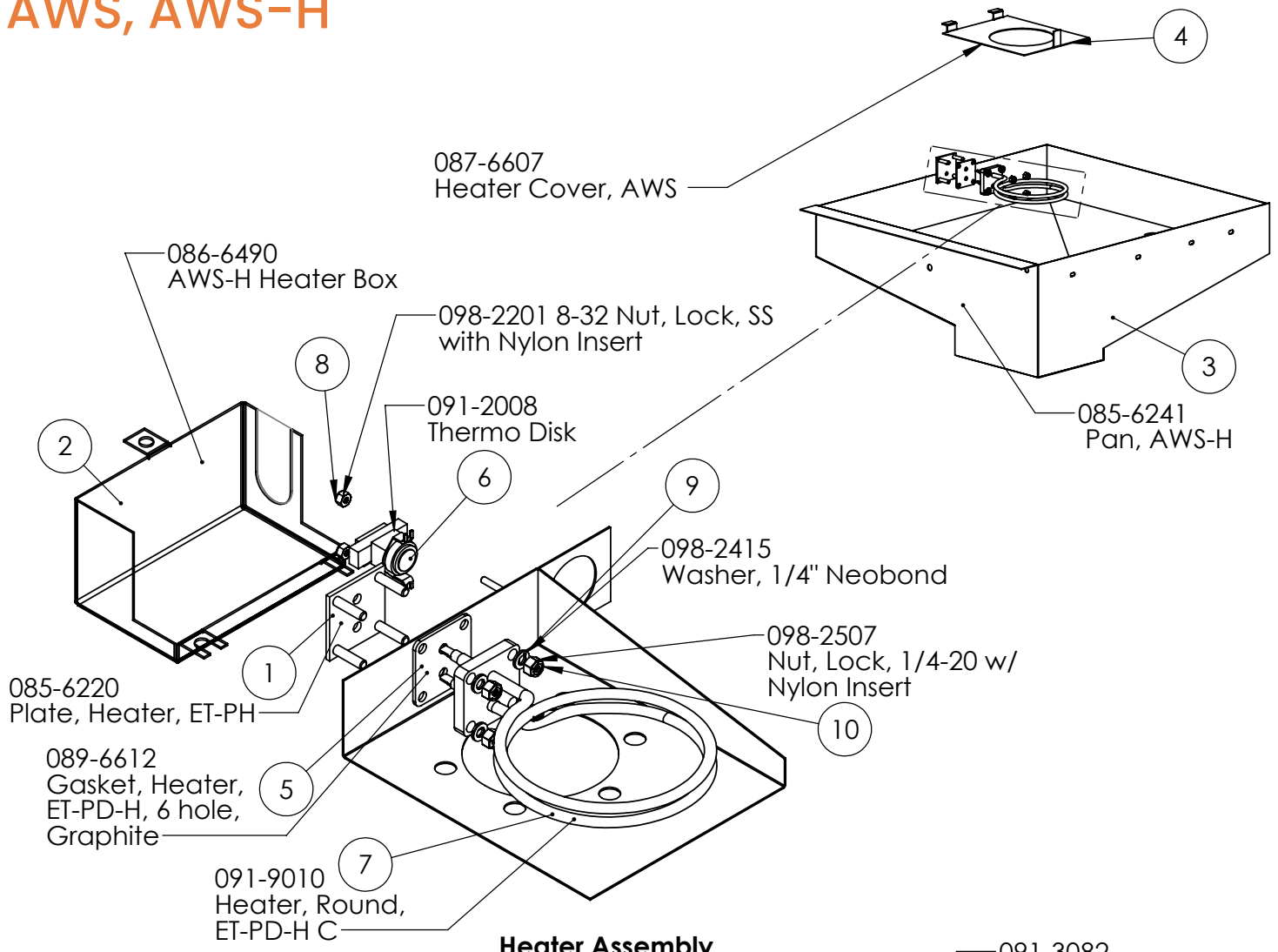

Cont. on Next Page

Heater Option Additional Components

Bill of Materials

Ref. No.	Part No.	No. Req.	Description
1	085-6220	1	Plate, Heater, ET-PH
2	086-6490	1	Heater Box Cover, AWS
3	085-6241	1	Pan, AWS-H
4	087-6607	1	Heater Cover, AWS-H
5	089-6612	1	Gasket, Heater, ET-PD-H, 6 Hole, Graphite
6	091-2008	1	Thermo Disk, ET-PH & ASQ
7	091-9010	1	Heater, Round, ET-PD-H C
8	098-2201	2	8-32 Nut, Lock, SS with Nylon Insert
9	098-2415	4	Washer, 1/4" Neobond
10	098-2507	4	Nut Lock, 1/4"-20 with Nylon Insert
Additional Controls Components for AWS-H			
11	291-3005	1	Relay, Cube, DPDT, 110 Volt, ADC44/66, N
12	291-3009	1	Socket, Relay, Din Rail N
13	091-3082	1	Contactator, Heater "ET Series"
14	085-6647	1	Lower Spray Base, AWS-H
15	085-6343	1	Y-Pipe Weldment AWS-H
16	087-6279	1	Upper Spray Manifold AWS-H

Heater Option Additional Components (Cont.)

AWS, AWS-H

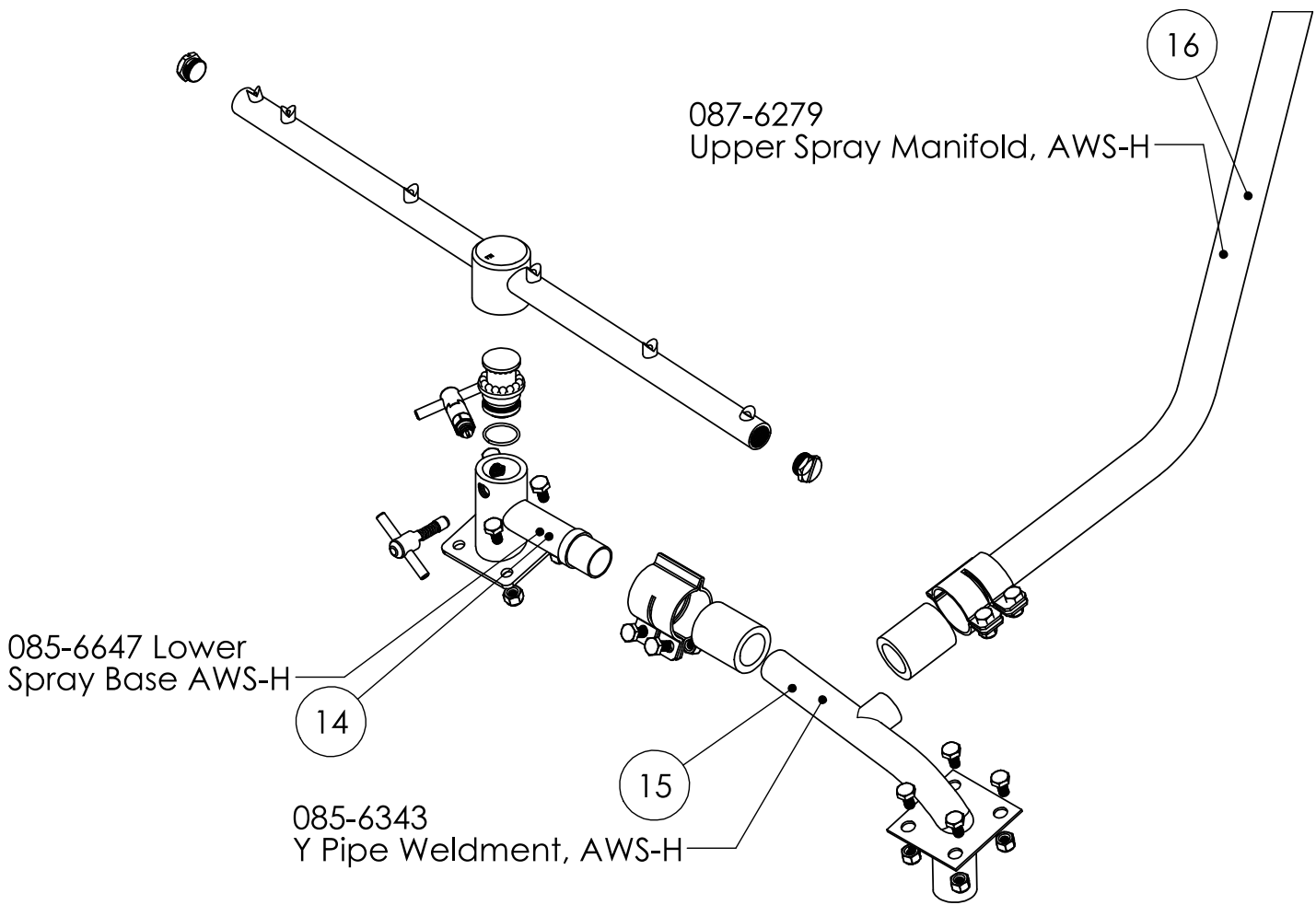

Heater Option Additional Components

Bill of Materials

Ref. No.	Part No.	No. Req.	Description
1	085-6220	1	Plate, Heater, ET-PH
2	086-6490	1	Heater Box Cover, AWS
3	085-6241	1	Pan, AWS-H
4	087-6607	1	Heater Cover, AWS-H
5	089-6612	1	Gasket, Heater, ET-PD-H, 6 Hole, Graphite
6	091-2008	1	Thermo Disk, ET-PH & ASQ
7	091-9010	1	Heater, Round, ET-PD-H C
8	098-2201	2	8-32 Nut, Lock, SS with Nylon Insert
9	098-2415	4	Washer, 1/4" Neobond
10	098-2507	4	Nut Lock, 1/4"-20 with Nylon Insert
Additional Controls Components for AWS-H			
11	291-3005	1	Relay, Cube, DPDT, 110 Volt, ADC44/66, N
12	291-3009	1	Socket, Relay, Din Rail N
13	091-3082	1	Contactator, Heater "ET Series"
14	085-6647	1	Lower Spray Base, AWS-H
15	085-6343	1	Y-Pipe Weldment AWS-H
16	087-6279	1	Upper Spray Manifold AWS-H

American Dish Service

**Manufacturer of low and high temperature Commercial
Dishwashers and Glasswashers**

900 Blake Street | Edwardsville, Kansas 66111
Phone: 913.422.3700 | Toll-Free: 800.922.2178 | Fax: 913.422.6630
orders@americandish.com | americandish.com



an Ali Group Company



The Spirit of Excellence