

CONVEYOR ADC-44



**HIGH* or LOW Temp the
Choice is Yours**

Energy saving, high-capacity conveyor

Captive End Caps

- Flip open, snap shut
- Shortens the cleaning process & eliminates down time

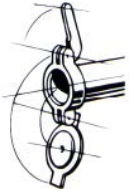

STANDARD FEATURES

- 244 Racks per hour
- Operates ONLY when racks are inserted
- Unrivaled cleaning ability
- Dual rinsing system
- User friendly conveyor
- Uses as little as 0.49 gallons per rack

Water Curtain Equipped

- Activates prior to final rinse
- Initiates the rinsing process and acts as a shield between tanks



Drain Pump Filter

- 2 stage pump strainer
- Eliminates wash pump obstructions and clogged jets
- Functions as drain stopper

Dual - Fail Safe Heater Control

- Precise water control mechanism
- Only allows heaters to operate when tank is full
- Unaffected by heavy soil, water action, strong chemicals and lime build-up



Fail - Safe Conveyor System

- Eliminates damaged racks
- Slip clutch design - stops rack movement
- Once removed operation easily resumes

© American Dish Service

900 Blake Street | Edwardsville, Kansas, 66111
Phone: 913.422.3700 | Toll-Free: 800.922.2178 | Fax: 913.422.6630
orders@americandish.com | americandish.com

For detailed specifications, go to
www.americandish.com

CONVEYOR ADC-44

Standard Features

- Auto fill
- No operator controls
- Energy saving stage washer
- Low water consumption
- No circuit boards
- Quiet operation
- Rack saving conveyor drive
- 244 racks per hour
- 360 sq. in. of washing action
- Auto cut-off
- High capacity heaters
- Self-purging
- Wide opening access doors
- 11 gallon wash tank with safety interlock
- 3 HP wash pump
- Skirted motor compartment
- Dual rinsing system
- Heavy stainless steel construction

All these features are Standard on the ADC-44. While other manufacturers may offer these same features as "Add-Ons"... at American Dish our machines are **COMPLETE & READY TO RUN.**



ADC-44 Specifications

U.S. REGISTERED PATENTS

ADC-44	Family Models (left or right feed)	
	ADC-44 Hot Temp	ADC-44 Chemical
NSF Rated Capacity (Racks/Hr.)	244	244
Conveyor Speed (ft/min)	6.8 (2.07 M)	6.8 (2.07 M)
Water Consumption (Gal/Rack)	0.49 (1.8 L)	0.49 (1.8 L)
Final Rinse Temperature (20 psi)	180° F (88.2° C)	120° F (48.8° C)
Sanitizer (Water / Chlorine)	180° F (88.2° C)	50 ppm
Electrical Power Supply	208/240V, 3PH, 60 AMP, 60HZ 3 Phase installation requires 6 gauge wires, a suitable ground, and a clean circuit.	
	1 PH, 50/60 AMP, 60 HZ 1 Phase installation requires one (1) 50 AMP service using 8 gauge wires with a 10 gauge neutral wire, and one (1) 60 AMP service using 6 gauge wires and a suitable ground, both on clean circuits.	
Motor Ratings	3 HP Wash, 1/3 HP Rinse, 1/3 HP Conveyor	
Heater Ratings	12 KW Wash, 2.25 KW Rinse	
Rack Size	Standard 19.75" x 19.75" (50.2 x 50.2 cm)	
Access Door Clearance	15" x 24.5" (38.1 x 62.2 cm)	
Rack Clearance (through machine)	19.25" x 20.75" (48.9 x 52.7)	
Water Inlet	0.75" F.P.T.	
Drain Size	2.0" F.P.T.	
Height (through machine)	73.75" (187.3 cm) (81.25" / 206.3 cm with control box open)	
Width (overall)	64" (162.5 cm)	
Width, Table to Table	44" (111.7 cm)	
Depth	30" (76.2 cm)	
Shipping Weight STD/BoBooster	760 lb/856 lb (344.73 kg/388.275 kg)	
Shipping Dimensions (STD)	72"L x 36"W x 80"T (182.9 cm x 91.4 cm x 203.2 cm)	
Shipping Dimensions (BoB)	72" L x 36" W x 80" H (182.9 cm x 91.4 cm x 207.7 cm)	

RIGHT FEED
(W/O VENT OPTION)

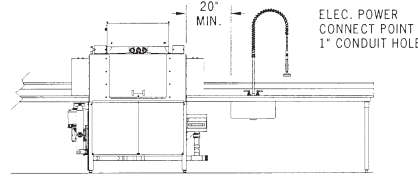

TOP VIEW OF LEFT FEED

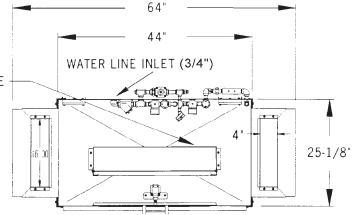

IMPORTANT NOTES

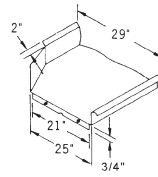

Both clean and soiled tables are to be bolted to the dishmachine with the 1/4-20 x 1/2" bolts and nuts provided. Leaks cause potential problems in electrical and mechanical areas under the machine. Quick drains (table)scuppers are not compatible with stage type conveyor dishmachines. Scrap sinks shall be no closer than 20" minimum from the dishmachine end of table.

The clean exit table should be at least 72" straight for efficient conveyor operation. Electrical and plumbing connects should be made by a qualified service person who will comply with all appropriate state and local health, electrical, plumbing, and safety codes. Manufacturer reserves the right to modify these specifications in compliance with regulatory agencies and manufacturing expediency.

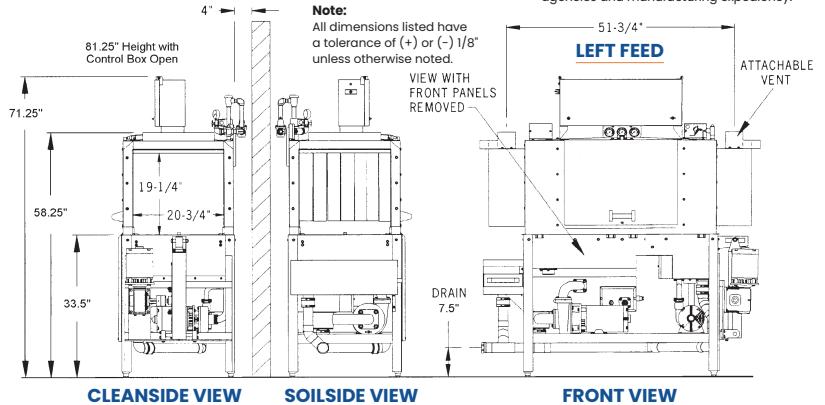

*Requires external hot water source that will provide at least 120 gallons of 180 degree water an hour

Effective 2/2023

Warning: Cancer and Reproductive Harm - www.P65Warnings.ca.gov



© American Dish Service

900 Blake Street | Edwardsville, Kansas, 66111
913.422.3700 | Toll-Free: 800.922.2178 | Fax: 913.422.6630
orders@americandish.com | americandish.com