

ADC-44 TALL Specifications

U.S. REGISTERED PATENTS

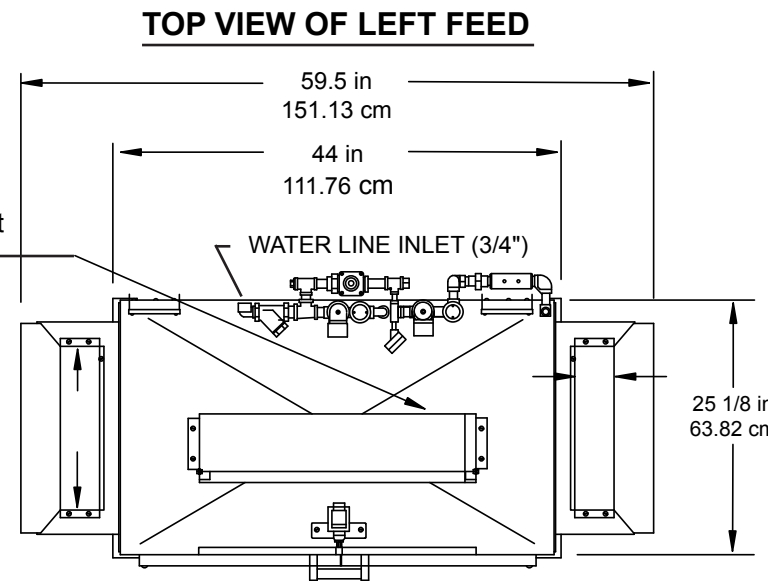
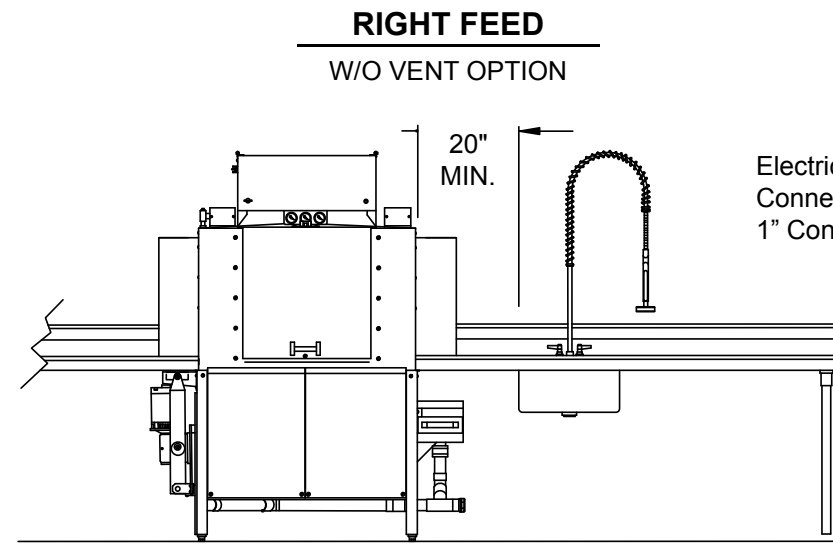

IMPORTANT NOTES

Both clean and soiled tables are to be bolted to the dishmachine with the 1/4-20 x 1/2" bolts and nuts provided.

Leaks cause potential problems in electrical and mechanical areas under the machine.

Quick drains (table scuppers) are not compatible with stage type conveyor dishmachines.

Scrap sinks shall be no closer than 20" minimum from the dishmachine end of the table.

The clean exit table should be at least 72" straight for efficient conveyor operation.

Electrical and plumbing connections must be made by a qualified service person who will comply with all appropriate state and local health, electrical, plumbing, and safety codes.

The Manufacturer reserves the right to modify these specifications in compliance with regulatory agencies and manufacturing expediency.

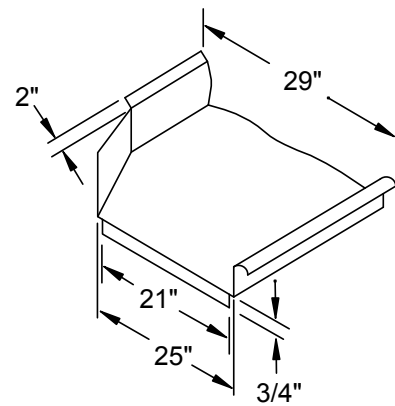

NOTE:

All dimensions listed have a tolerance of + or - 1/8" unless otherwise noted.

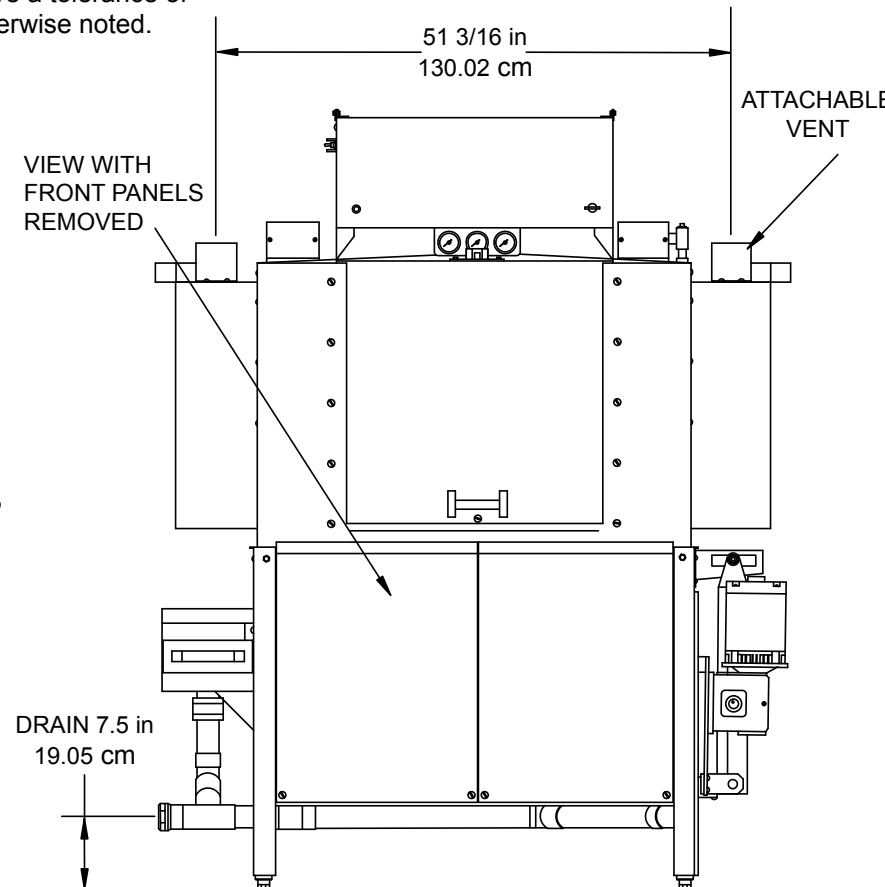
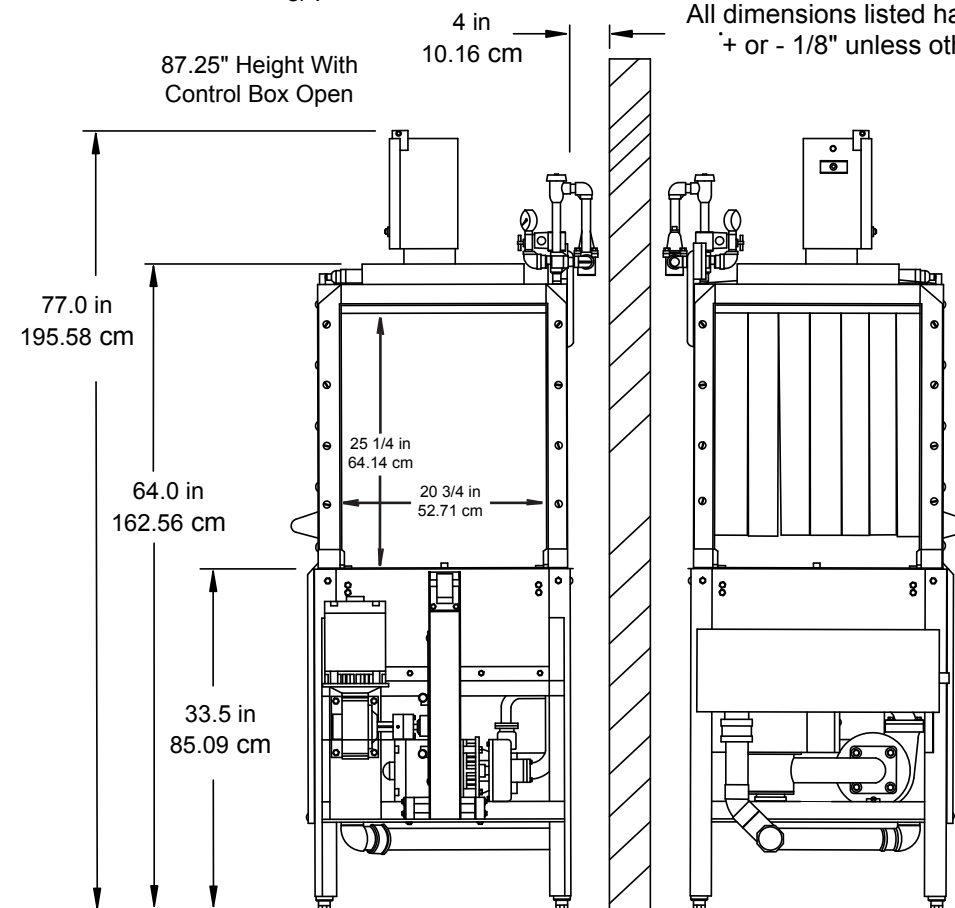

CLEANSIDE VIEW

SOILSIDE VIEW

FRONT VIEW

ADC-44 TALL

Family Models (left or right feed)

Hot Temp Chemical

NSF Rated Capacity 244 rack/hr 244 rack/hr

Conveyor Speed (ft/min) 6.7 (2.04 M) 6.7 (2.04 M)

Water Consumption (Gal/Rack) 0.49 (1.8 L) 0.49 (1.8 L)

Final Rinse Temperature (20 psi) 180° F (82.2° C) 120° F (48.8° C)

Sanitizer (Water / Chlorine) 180° F 50 ppm

Electrical Power Supply **208/240V, 3PH, 60 AMP, 60HZ**

3 Phase installation requires 6 gauge wires, a suitable ground, and a clean circuit.

1 PH, 50/60 AMP, 60 HZ

1 PH, 50/60 AMP, 60 HZ 1 Phase installation requires one(1) 50 Amp service using 8 guagewires with a 10 gauge nuetral wire, and one(1) 60 Amp serviceusing 6 gauge wires and a suitable ground, both on clean circuits.

Motor Ratings 3 HP Wash, 1/3 HP Rinse, 1/3 HP Conveyor

Heater Ratings 12 KW Wash, 2.25 KW Rinse

Rack Size Standard 19.75" x 19.75" (50.2 x 50.2 cm)

Access Door Clearance 21" x 24.5" (53.34 x 62.2 cm)

Rack Clearance (through machine) 25.25" x 20.75" (64.13 x 52.7)

Water Inlet 0.75" F.P.T.

Drain Size 2.0" F.P.T.

Height (through machine) 85.75" (217.81 cm)
(87.25" / 554.62 cm with control box open)

Width (overall) 59.5" (151.13 cm)

Width, Table to Table 44" (111.7 cm)

Depth 30" (76.2 cm)

Shipping Weight 780 lb (353.8 kg)

Shipping Volume (crated) 128.7 cu. ft. (3.64 cu. meters)