

IMPORTANT NOTES

Both clean and soiled tables are to be bolted to the dishmachine with the 1/4-20 x 1/2" bolts and nuts provided.

Leaks cause potential problems in electrical and mechanical areas under the machine.

Quick drains (table scuppers) are not compatible with stage type conveyor dishmachines.

Scrap sinks shall be no closer than 20" minimum from the dishmachine end of the table.

The clean exit table should be at least 72" straight for efficient conveyor operation.

Electrical and plumbing connections must be made by a qualified service person who will comply with all appropriate state and local health, electrical, plumbing, and safety codes.

The Manufacturer reserves the right to modify these specifications in compliance with regulatory agencies and manufacturing expediency.

NOTE:

All dimensions listed have a tolerance of + or - 1/8" unless otherwise noted.

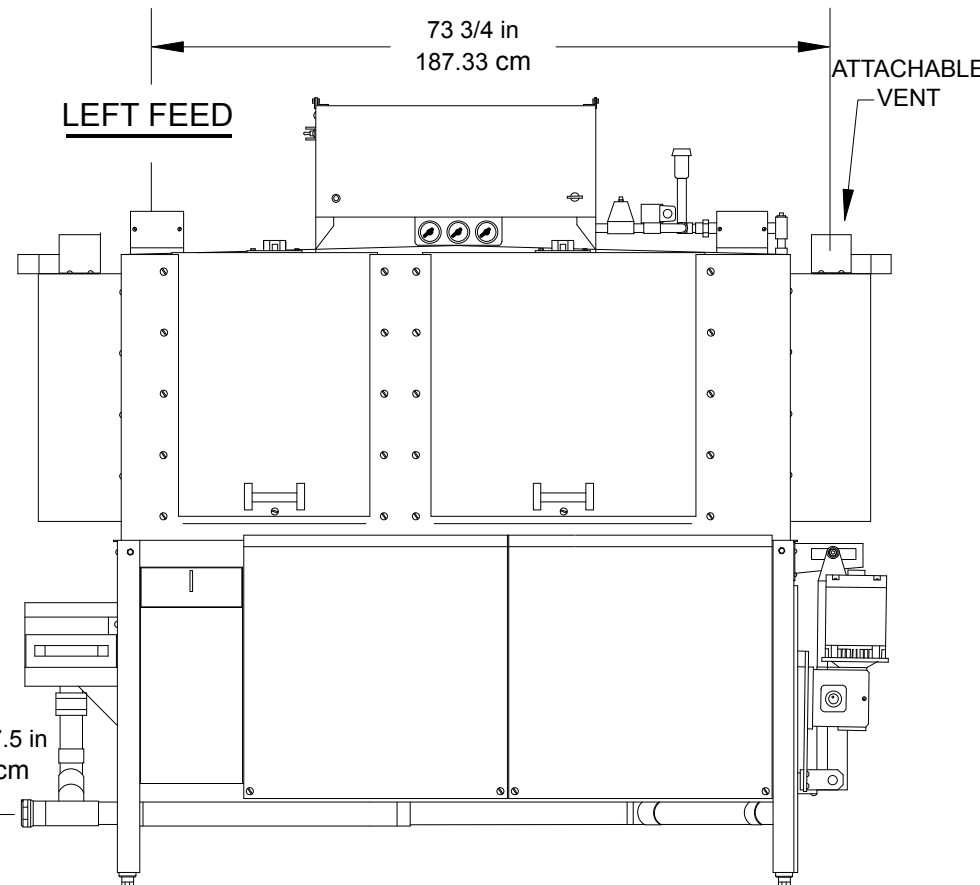
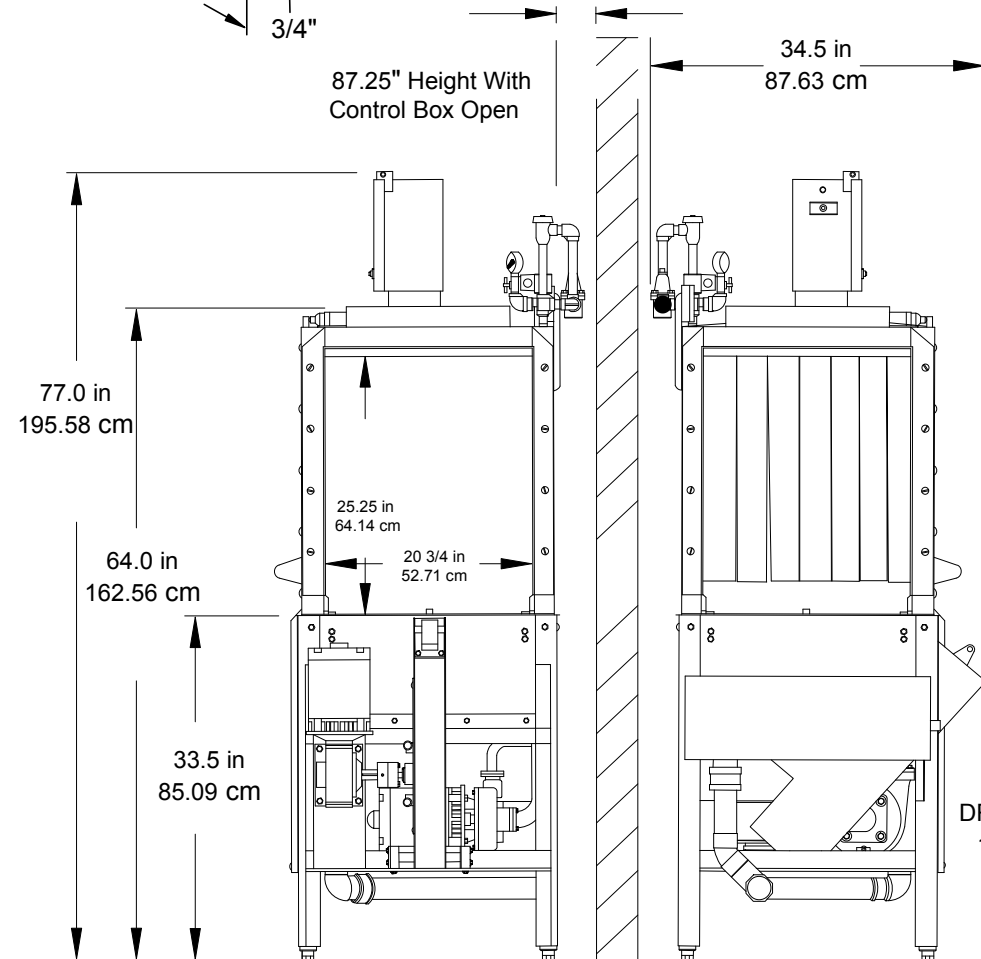

CLEANSIDE VIEW

SOILSIDE VIEW

FRONT VIEW



ADC-66 TALL Specifications

U.S. REGISTERED PATENTS

ADC-66 TALL	Family Models (left or right feed)	
	Hot Temp	Chemical
NSF Rated Capacity	244 rack/hr	244 rack/hr
Conveyor Speed (ft/min)	6.7 (2.07 M)	6.7 (2.07 M)
Water Consumption (Gal/Rack)	0.49 (1.8 L)	0.49 (1.8 L)
Rinse Temperature (20 psi)	180° F (82.2° C)	120° F (48.8° C)
Sanitizer (Water / Chlorine)	180° F	50ppm
Electrical Power Supply	.208/240V, 3PH, 90 AMP, 60HZ <i>3 Phase installation requires 3 guage wires with a 10 gauge neutral wire, a suitable ground, and a clean circuit.</i>	
Motor Ratings	1-1/2 HP Scrap, 3 HP Wash, 1/3 HP Rinse, 1/3 HP Conveyor	
Heater Ratings	18 KW Wash, 2.25 KW Rinse	
Rack Size	Standard 19.75" x 19.75" (50.2 x 50.2 cm)	
Access Door Clearance	15" x 24.5" (38.1 x 62.2 cm)	
Rack Clearance (through machine)	25.25" x 20.75" (64.14 x 52.7 cm)	
Water Inlet	(0.75") F.P.T.	
Drain Size	(2.0") F.P.T.	
Height (with door open)	79.75" (202.57 cm) (87.25" / 221.62 cm with control box cover open)	
Width (overall)	86" (218.4 cm)	
Width, Table to Table	66" (167.6 cm)	
Depth	34.5" (87.6 cm)	
Shipping Weight	978 lb (444 kg)	
Shipping Volume (crated)	176 cu. ft. (6.44 cu. m.)	