

## INSTALLATION INSTRUCTIONS

# Model HT-25

**208v/240v, 3-Phase, 40a/5-Wire, Neutral**

**High Temp Dishmachine with Built-On Booster Combo 208v/240v, 3-ph, 5-wire, 50a**

Listed by UL #E68594, NSF/ANSI 3, ASSE 1004 #933, LA Test Labs File M-780089, Mass. License P3-0111-306



**DANGER**

The electrical power supplied to this machine is an imminent hazard that could result in severe bodily injury or death if not properly installed or hooked up correctly. When working in the control box or on electrical parts, always disconnect power and tag-out before servicing. Replace cover to control box and other protective covers when finished servicing this equipment.

© **American Dish Service**

900 Blake Street | Edwardsville, Kansas 66111  
Phone: 913.422.3700 | Toll-Free: 800.922.2178 | Fax: 913.422.6630  
orders@americandish.com | [americandish.com](http://americandish.com)

If you have questions, call 800-922-2178 or  
visit our website at  
[www.americandish.com](http://www.americandish.com)



## CAUTION

Read manufacturer's manual before using this product. For your safety read and observe all cautions shown throughout these instructions. While performing installations described in this booklet, wear approved personal protective equipment, including safety eye-wear.

**CHEMICALS**—There are potentially hazardous situations when working with industrial cleaning chemicals for dishmachines. See chemical manufacturer's SDS sheets and safe practices for handling and installing chemical feeders and supply containers.



**WARNING:** Cancer and Reproductive Harm – [www.P65Warnings.ca.gov](http://www.P65Warnings.ca.gov)

## NOTICE

**#1 BEFORE YOU BEGIN**—American Dish Service provides this information as a service to our customers. Keep all instructions for future reference. ADS reserves the right to alter or update this information at any time. Should you desire to make sure that you have the most up-to-date information, we would direct you to the appropriate document on our web site: [www.americandish.com](http://www.americandish.com). Set out below are the specifications and requirements that you must use and follow to properly install the type or types of equipment listed above. It is your obligation as the customer to ensure that the machine is installed safely and properly, and when completed, the machine is left in proper and safe working order. Electrical, Plumbing, and Chemical hookup should be performed by a qualified professional who will ensure that the equipment is installed in accordance with all applicable Codes, Ordinances, and Safety requirements. Failure to follow the installation instructions could void the warranty. ADS assumes no liability or control over the installation of the equipment. Product failure due to improper installation is not covered under the ADS Warranty.

**#2 This equipment is considered an item of heavy use. It is not rated for outdoor use.**

**#3 SPRAY ARMS**—Do not install spray arms until machine is flushed with water. When this machine is connected to power, it will normally fill with water and complete one cycle. Do this without the spray arms. Dump that water out before installing spray arms. Draining the water will flush installation debris from the tank and pump; this prevents damage to spray arm bearings. To drain, pull the pump filter out of the sump.

**#4 IMPORTANT**—Dishmachines must be installed to allow for servicing of motor and plumbing. Do not install chemical dispensers on the top of the control box or machine.

**#5 WATER HEATERS OR BOILERS**—Must provide the minimum temperature of 120°F required by the machine listed above, which has a minimum demand of 61.2 gallons per hour. These specifications are for the dishmachine only, which typically accounts for 70% of a restaurant's hot water demand.

**FOR HOT WATER SANITIZING**—An additional booster heater must be installed to reach 180°F minimum for the final rinse. This booster will require a rise of 70°F. (The HT-25 does not have an internal booster heater, but ADS offers a combo package with a booster built-on to the left side of the machine and wired for a single point electrical connection. The combo option is only available in 3-phase electrical power.)

**#6 INSPECT FOR DAMAGE**—If you receive a damaged dishmachine, do not sign "Clear" but write "Damaged" on the documents.

# ELECTRICAL SECTION



The electrical power supplied to this machine is an imminent hazard that could result in severe bodily injury or death if not properly installed or hooked up correctly

## NOTICE

**Before powering up the machine, CHECK ALL ELECTRICAL SCREW TERMINALS** in the control box on top of the machine and the heater box. Screws can loosen in transit. Loose connections on high amp load terminals will cause wire burning and component damage during operation and will not be covered under ADS warranty. The term “Clean Circuit” means the electrical circuit breaker supplies no other devices, motors, machines, or lights.

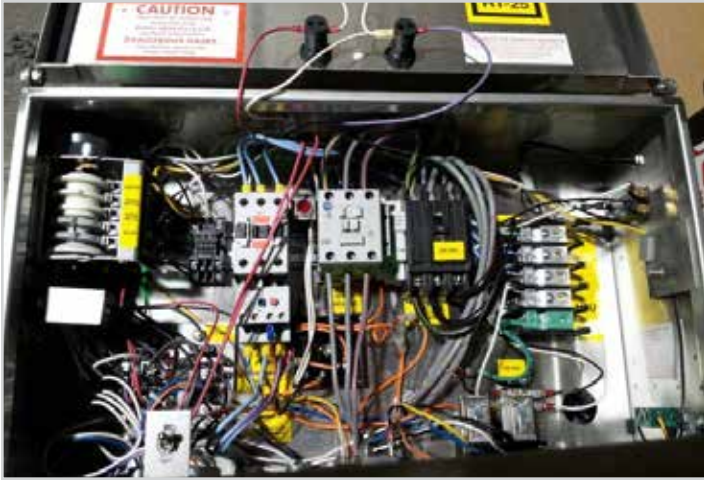

Showing HT-25, 5-wire control box



Main distribution block for incoming 5-wire

## Electrical: HT-25/34 with Built-On Booster (3-Phase, 50a/5-Wire, Neutral Wire)

**ORDERING INSTRUCTIONS—Machines with heaters are voltage specific, order according to the actual voltage available at the installation (see kW chart in the Appendix)**

**IT IS RECOMMENDED THAT THIS EQUIPMENT BE INSTALLED USING A NEW CIRCUIT BREAKER.**

The power supply of 208 volts, 3-phase, 50-amps must consist of three 8-gauge wires, one Neutral and one suitable green ground wire. This is called a 5-wire connection. This is a single electrical connection point for both dishmachine and the attached booster combination when purchased from the factory. The 50-amp breaker or fuses must be on a clean circuit to the machine. ADS has provided a 1" conduit hole (1-3/8" actual size) for electrical service in the back of the control box. Attach the 8-gauge wires to terminals marked L1, L2, & L3 on the main distribution block in the control box. Attach a 10-gauge white neutral and green ground wire to their proper locations on the main distribution block marked NEU and GND, then tighten all wires. This model has 120v control circuit and components.

**THIS MODEL IS ALSO AVAILABLE WITHOUT A BOOSTER AT 40 AMPS.**

**FOR 240 VOLT OR DELTA SYSTEMS**—attach the high leg (200 volt line) to L3. Attach your 120 volt lines to L1 and L2. If power is 240v, see kW rating chart at the back of the manual for correct heater sizing and available ADS heater elements.

**3-Phase MOTOR ROTATION**—Remove front panels and check rotation of motors. A rotational arrow is placed on the wash pump motor. If this motor is running in reverse of the arrow, turn off main power and switch the incoming power wires on L1 & L2. Verify proper rotation and tighten all wires.

## BUILT-ON BOOSTER COMBO

**ELECTRICAL**—The combo package uses an inter-latch circuit to turn off the dishmachine sustainer heater anytime the booster turns on. In this feature, there is only one heater circuit energized at a time—allowing both booster and dishmachine to be installed on one 50a service.

Connections in the booster heater come from the HT-25/34 control

box. The gray 3-phase power wires come from the 50a breaker in the HT-25/34 control box and connect to the incoming side of the booster contactor. The single yellow wire connects to the heater side of the contactor on the LI terminal circuit. Then the yellow wire connects in the HT-25/34 box to the relay controlling the dishmachine sustainer heater. The dishmachine and booster combination come pre-wired from the factory.

**EXCEPTION**—HT-25/34 with booster combo is **NOT AVAILABLE** in single-phase the heater side of the contactor on the LI terminal circuit. Then the yellow wire connects in the HT-25/34 box to the relay controlling the dishmachine sustainer heater. The dishmachine and booster combination come pre-wired from the factory.



Showing booster contactor, yellow signal wire



Yellow signal wire from the booster controls heater relay

## PLUMBING SECTION

### NOTICE

**#1 TANKLESS WATER HEATERS** can be problematic for commercial dishmachines. The ADS model HT-25 dishmachine require heated water 61.2 gallons per hour at 20 psi as measured at the final rinse manifold, with a minimum temperature of 120°F. It has been the experience of ADS that tankless supply systems require multiple units plumbed in sequence with a recirculation loop to achieve proper pressure and temperature.

Check with the tankless water heater manufacturer, they may recommend a storage tank to guarantee proper flow and line pressure to the machine. Failure to provide adequate water quantity, pressure and temperature to the machine will cause the machine to function improperly and is not the responsibility of ADS. Improperly installing ADS equipment in this manner could void the warranty. All costs associated with providing an adequate water supply to the machine is the sole responsibility of the user.

**#2 DRAIN SIZE**—Gravity drain lines are 2" pipe size. Do not use reducing adapters for drain lines, always use same diameter pipe or larger. Close pump petcocks if equipped.

**#3 A PRESSURE REDUCING** valve with by-pass should be installed before the booster heater if the line pressure is 50 psi or above. This is according to booster manufacturer's instructions.

**#4**  **BURN HAZARD** from hot water from pumped sprays or plumbing leaks.

**#5**  **ELECTRICAL SHOCK HAZARD** on bare electrical terminals in the thermostat box or control box.

**#6 HOODS**—Follow all local plumbing and mechanical codes. IMC 2012, section 507.2.2 requires Type II hoods for all commercial dishwashers except where the heat and moisture loads are incorporated into the building's HVAC systems or dishwashing equipment designed with separate heat and moisture removal systems. A door-type, single-rack, hot-water sanitizing dishwasher is rated at 4770 Btu/h by table 5E, ASHRAE Research Project #1362, 8/5/2008. **ADS DOES NOT SPECIFY BUILDING HVAC VALUES.**



Showing final rinse mixing chamber, hot-water inlet to HT-25



Data plate information and listing marks

## Hot Water Sanitizer Connection

Flush the building's water lines before connecting to the dishmachine to avoid fouling the inlet water solenoid. For high temp sanitizing this inlet water line must come from a stand-alone booster heater or the ADS HT-25/34 w/built on booster. Connect 3/4" MPT water supply line to the booster for the combo or a 1/2" MPT to the top of the dishmachine inlet manifold when using a stand-alone booster. The requirement at the dishmachine is 180°F minimum at 20 PSI during final rinse, with a demand of **61.2 GPH**. The pressure is measured at the pressure gauge mounted next to the pressure reducing valve in the inlet plumbing on top of the machine's hood. To adjust pressure, turn adjustment screw atop the valve counter-clockwise to decrease pressure.



Showing PRV, ASSE approved air-gap, final rinse gauge



Showing built-on booster mounted in corner position (front)

**BUILT-ON BOOSTER COMBO PLUMBING**—Incoming hot water attaches to the lower 3/4" inlet on the booster heater. This should come from the building's hot water heater. The dishmachine and booster come pre-plumbed from the factory and pre-wired. The only connection is the incoming hot water to the booster. A pressure reducing valve with by-pass should be installed before the booster heater if the line pressure is 50 psi or above.



HT hot water inlet ball valve, connected to booster line



Booster hot outlet line going up to HT-25/34 inlet manifold

## Chemical Sanitizer Connection

For chemical sanitizing the hot water line will come directly from the building's water heater. Connect 1/2" MPT water supply line to the inlet manifold. The requirement at the dishmachine is 120°F minimum at 20 PSI during final rinse, with a demand of **61.2 GPH**. The pressure is measured at the pressure gauge mounted next to the pressure reducing valve in the inlet plumbing on top of the machine's hood. To adjust pressure, turn adjustment screw atop the valve counter-clockwise to decrease pressure. A chemical dispenser must be added that has a third pump for chlorine.

## Drain Requirements

ADS provides a 2" copper drain manifold for the tank and scrap box, the manifold is shipped strapped to the pallet of the dishmachine. After installation, attach the drain manifold using the rubber "no-hubs" on the manifold. To prevent clogging, run drain lines as straight as possible. Do not plumb with tight radius elbows or 180-degree bends. Use of floor sinks for drains can cause flooding. Do not use reducing adapters for drain lines, always use 2" diameter pipe or larger. Always run gravity drain lines downhill.



Scrap box and 2" drain manifold attached to pallet for shipping



Drain sump connection for copper drain, bottom of tank



HT-25 drain manifold with "no-hub" connectors



Pump filter in drain sump

# DISPENSER HOOK-UP



## WARNING

**You must wear approved safety eye-wear before connecting chemicals equipment. Commercial cleaning chemicals are highly concentrated, they can cause damage to mechanical and electrical parts of the dishmachine. Do not mount dispensers on top of the control box or run chemical lines over controls or plumbing. Always secure chemical lines and check regularly for leaks. If not properly handled, chemicals can cause serious bodily injury. In the event of chemical contact to skin or eyes; wash immediately with fresh water and seek medical attention.**

**CONTAINERS:** When a chemical delivery system is connected to the ADS high temp dishmachine using 5-gallon pails for industrial ware-washing chemical products, these must be equipped with Closed Loop containers. Always use chemical resistant safety gloves and safety goggles (indirect-vented or non-vented) when changing chemical buckets. Immediately report spills and refer to your chemical suppliers SDS safety data sheet or SDS material safety data sheet for information if chemical come in contact with skin or eyes.

Any modifications to the chemical delivery system for smaller containers must include **Closed Loop Chemical Containers** (spill proof bottles) in a secured racking system. It is the responsibility of the user of the machine to purchase chemicals in spill proof containers. **FAILURE CAN RESULT IN SERIOUS INJURY.** Never place chemicals in open containers or containers that can be easily tipped over when moving or changing product. Failure to do so will void your ADS warranty.

**There is NO CHEMICAL DISPENSER included with this model. Chemical dispensers must be provided and installed prior to operation. The installation of the dispenser is typically provided by the chemical supplier.**

## DE-LIME SWITCH

**The de-lime switch is placed inside of the control box to avoid unauthorized operations. Because of potentially hazardous gas resulting from the combination of chlorine with acid solution, only authorized trained individuals should be allowed to de-lime a commercial dishmachine.**

**INSTRUCTIONS FOR USING THE DE-LIME FEATURE ON A HT-25:** First turn off the machine then empty all water out of the machine by removing the pump filter/drain plug. After all water has emptied out, replace the pump filter/drain plug and fill the machine with fresh water by turning on the master switch. After the tank is filled and fill water has shut off, add the de-lime acid to the tank water. Turn on the de-lime switch to operate the pump motor. **READ THE DIRECTIONS ON THE CONTAINER FOR CORRECT CONCENTRATION OF THE CHEMICAL. TYPICAL CONCENTRATION LEVELS 1:20 TO 1:60.**

Let the machine run long enough to return the inside of the machine to the appearance of shiny metal surfaces. Then empty and refill the tank with fresh water. It is best to de-lime more often with milder acid solutions than waiting until there is heavy build up of white minerals, then trying to remove the build up with very strong acidic concentrations. Using too strong of an acid solution or running it for very long periods of time will erode the metal of the impeller because it is spinning in the acid solution. If the final rinse arms are clogged with mineral deposits, remove from the machine and soak them in a pan with lime remover.



De-lime switch in HT-25 control box



Warning decal about mixing chemicals



Impeller damaged from high acid solution



Mixing chamber with two 1/8" pipe threaded port



Showing 7/8" detergent probe hole behind pump motor

ADS provides two (2) ports, 1/8" IPS female threads in the final rinse mixing chamber for dispenser check valves. Probe hole (7/8") is provided in the wash tank for probe installations (install probe before operating the machine). Detergent hole (7/8") is provided for bulk-head fitting (install fitting before operating machine).



Showing back of tank, 7/8" detergent bulkhead fitting hole



Showing dispenser signal connection terminals

**NOTE: Before turning on the water, if the chemical dispenser has not been installed, plug the probe and chemical delivery holes in the wash tank and plug the mixing chamber injection ports.**

HT-25/34, 4-wire provides 230v dispenser signals. Connect to chemical dispenser terminal blocks located on the left-hand side of the control box, look for yellow decal labeled detergent and rinse. The dispenser wash signal comes from the 4th cam on the cam timer. This cam can be adjusted so a signal for detergent can be set for a certain time or limit during the cycle. The rinse signal comes from the 3rd cam, it last for 10 seconds and is not adjustable. The 5th cam is a spare for future features.

**TESTING FOR TEMPERATURE**—For high temp sanitizing, the measurement is taken at the manifold for a minimum of 180°F, NOT in or at the sprays. If tapes are used to verify temperature, then only 165°F labels should be used, this is the temperature required on the surface of the plates--NOT 180°F. This is according to the NSF/ANSI Standard 3 test protocol.



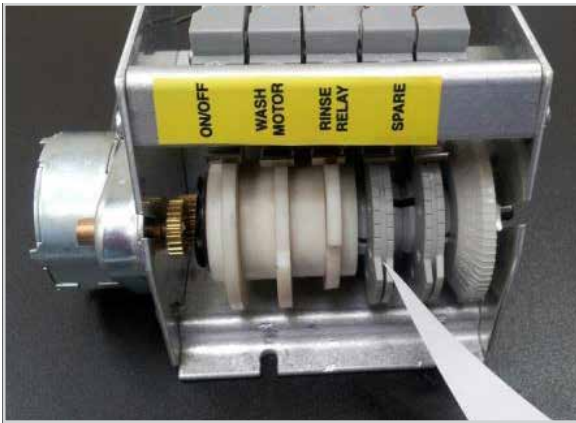

Showing HT-25 cam timer, arrow points to deter cam



Cam adjusting tool

**TYPE OF CHEMICALS**—Use only commercial grade low-energy chemicals. For proper operation, use non-foaming detergents and buffered sanitizers. Do not wash gold, pewter, silver, or silver-plate with chlorine based sanitizers. High concentrations of chlorine sanitizers and caustic detergents will cause damage to metals and welds. Do not exceed

50 parts-per-million (PPM) “free” or available chlorine, using higher than 50 ppm will be dependent on local health requirements, however, the increased chlorine will result in higher corrosion of metal parts.

**The resulting damage from overusing chlorine is not covered under the ADS warranty.** Purpose-built ware-washing dispensers are needed to properly meter chemicals for wash and rinse. These dispensers are not included with this model but must be provided by the company that provides the ware-washing chemicals. Manually adding industrial chemicals to the dishmachine is unsafe and not approved.

**HARD WATER**—Water softeners should be used to correct hard water conditions. Treating hard water conditions with acid solutions in the machine is discouraged. Hard water is often treated with more expensive dishmachine chemicals, but it is more effective and less destructive to the metal when the water is softened before it is used by the dishmachine.

## CHECK LIST PRIOR TO INITIAL START UP

Open doors and remove all packaging, including cardboard supports found under the wash tank heater. Do not dispose of packing material until you remove spray arms. Packing materials contain the installation manual, QC check sheets; upper and lower wash and rinse arms. Prior to connecting the main power supply, tighten all wire connections looking for those that loosened during shipping or moving. Before turning on the water, if the chemical dispenser has not been installed, plug the probe and chemical delivery holes in the wash tank and plug the mixing chamber injection ports. Turn on the water supply. Check and correct any leaks throughout the machine. After the first fill and completed cycle, drain the tank then install wash and rinse spray arms, both upper and lower. They are interchangeable top to bottom.



Showing spray arm base & transfer tube



Wash arm w/bearing installed on base



Final rinse arm twisted into transfer tube

Verify incoming water temperatures and final rinse pressure (20 psi during final rinse). Remove any of the white protective film from stainless surfaces such as doors or panels.

# DISHMACHINE OPERATIONAL TESTS



## WARNING

**BURN HAZARD FROM HOT WATER** Do not open doors while machine is in cycle. Doing so could result in serious bodily injury from spraying hot water and chemicals.

**TO OPERATE**—Connect the breaker for main power and turn “ON” the dishmachine master switch. Water will automatically fill to an operational level. After several cycles when final rinse water increases the tank water level, the tank water will overflow to the scrap box. Place a rack of dishes in the machine, close the door and the cycle will begin.



Showing thermostat and sustainer heater terminals\*



Showing “float” switch that controls fill water & heater

The wash temperature is maintained by a sustainer heater. Record tank temperature during the initial tests. There are two gauges mounted under the control box. Gauges are marked Wash/Final Rinse. Wash tank temperature should be 140°F for chemical sanitizing and 160°F for hot water sanitizing. If tank temperatures are low, increase by adjusting the heater thermostat located behind the wash motor.\*

Increase temp by turning center rod of the thermostat counter clock-wise or turn to left. Adjust thermostat in small increments (1/4 turn). Heater is switched off when water levels are low and the fill has been activated. Final rinse temperatures are 120°F for chemical sanitizers, and 180°F for hot water sanitizing. To increase the final rinse temperatures turn up the thermostat on the booster heater or water heater respectively. Do not set a booster heater above 195°F. **ADS DOES NOT SPECIFY BUILDING HVAC VALUES.**

**“FLOAT” AND SWITCH**—The float will not actually float. It is heavier than water but it weighs less in water than in air. This difference allows the return spring in the float switch to push out against the lever, which raises the float in water. In air the float weight will overcome the switch spring tension and drop down. The float switch (#291-3014) is specifically made with this spring tension so the water control system will operate correctly. Do not replace with a timer switch even though they look the similar.



Wash tank float and tank overflow

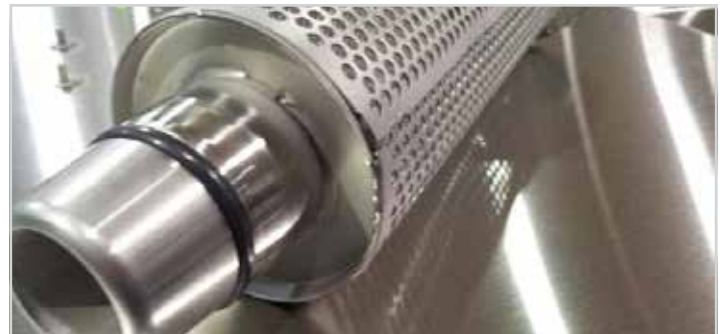

Pump filter and drain plug, note O-ring seal

## HT-25 WASH ARM BEARING REPLACEMENT OR CLEANING



Remove 4 screws and lift top shell



Remove top shell, exposing top bearing race



Top race removed, ball bearings for replacement



Races are interchangeable, capture shells are also

**IMAGES BELOW**—Showing repair of loose end cap when tab on the cap has been forced close or bent on material such as seeds or tooth picks.



Tab on endcap bent inward, causing loose fit



Straighten tab in line with the coin edge to tighten

# APPENDIX

089-9336---HT-25 Parts Manual  
 089-9451---Wire diagram  
 089-9345---Service Manual  
 089-9434---Brochure

089-9370---Wall Chart  
 089-9418---Spec Sheet  
 089-9377---Installation Manual HT-25 (5-wire)

## HT-25 SINGLE TANK HIGH TEMP

Voltage	Full Load	Amps
208v	3	30.2
240v	3	33.5

## HT-25 SINGLE TANK HIGH TEMP W/BOOSTER

Voltage	Full Load	Amps
208v	3	41.2
240v	3	36.9

Heaters are voltage specific, meaning voltage makes a difference in the wattage output of the heater. The following chart will list the wattage (kW) output for various available 3-phase voltages. Also listed are the ADS tank heaters available to match those voltages.

Heater Rated	Supplied Volts	Actual Output	Amp Draw	Phase
12kW 208v (291-9009)	200 volts	11.1 kW	32.0a	3-ph
	208 volts	12.0 kW	33.4a	3-ph
	240 volts	15.9 kW	38.4a	3-ph
12kW 220v (291-9001)	200 volts	9.9 kW	28.6a	3-ph
	208 volts	10.7 kW	29.7a	3-ph
	220 volts	12.0 kW	33.4a	3-ph
	240 volts	14.3 kW	34.4a	3-ph
8kW 208v (391-9001)	200 volts	7.4 kW	21.4a	3-ph
	208 volts	8.0 kW	22.2a	3-ph
	220 volts	8.9 kW	23.4a	3-ph
	240 volts	10.6 kW	25.5a	3-ph

Normal tank heater for HT-25, single-phase is 208v, 8kW\*, 240v, 8kW is special order

# ADS Wire Chart (Ladder)

## Model: HT-25/34 Including all options of 2005

For 3-phase, 208-240v Power

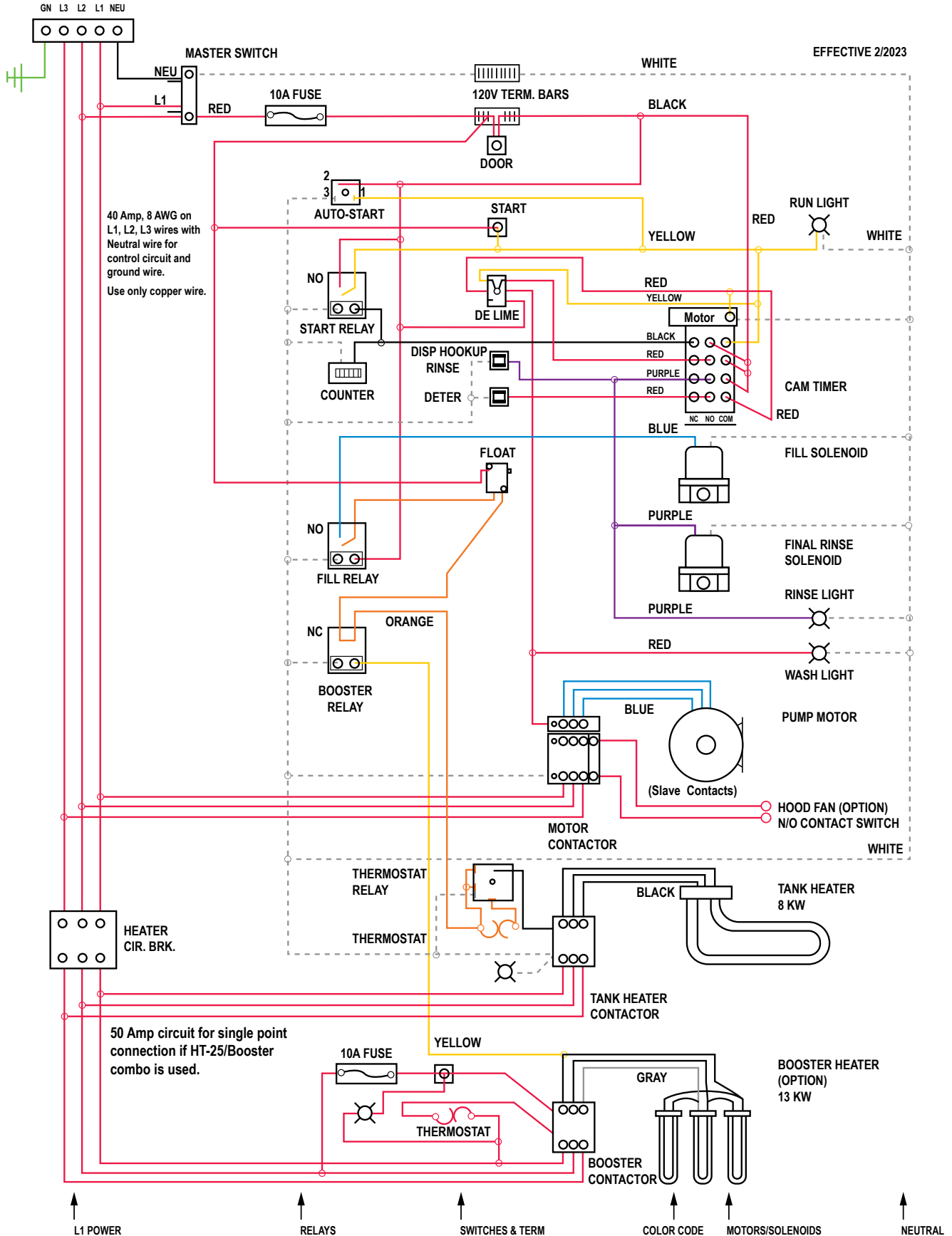



# WARNING!

This product is manufactured solely for **commercial** use.  
It is not to be used in residential installations of any kind.  
Doing so will immediately void all warranties.  
American Dish Service assumes no liability for such  
unintended uses.

---

**FOR PARTS & SERVICE  
MANUALS GO TO**

**[www.americandish.com](http://www.americandish.com)**

---



# PRODUCTION FINAL INSPECTION

Model: HT-25



SERIAL #: \_\_\_\_\_ MODEL #: \_\_\_\_\_ DATE: \_\_\_\_\_

- 1. Clean out all grit and shavings from inside, clean under tank heater also. Level machine
  - 2. Connect power source, leave heater c/b and motor contactor off
  - 3. Fill tank by turning on master switch
  - 4. Check tray track (no binding)
    - a. Door moves easily and gently, up and down
    - b. Final rinse: clear jets, check for leaks at manifold
  - 5. Check timer, finger movement and shut off of master, wash, and rinse
    - a. Check timer with order -- 45 sec or 60 sec
  - 6. Check all studs (should not deform metal by drawing down on torque)
  - 7. Turn on heater c/b, let tank equalize to temp. (Must maintain temp. through 5 operations)
    - a. Adjust thermostats to:
      - 120°F min. wash for Chemical Sanitizing
      - 160°F min. wash for Hot Temp
      - 180°F min. for booster heater
    - b. Calibrate thermometers with thermocouple tester
  - 8. Check door for leaking when wash pump is operated
  - 9. Easy movement and rotation of spray arm as they are installed or removed for cleaning
  - 10. Scrap trays fit without binding or excessive gaps.
  - 11. Check screws on bearing shells, no cross thread or slot deformation
  - 12. Turn on heater circuit breaker
    - a. Check amp draw on each leg: wash heater:
      - 21a-23.3a, 8kw, 3PH-208v
      - 18.2a-20.1a, 8kw, 3PH-240v
      - 36.6a-40.4a, 8kw, 1PH-208v
      - 31.6a-34.9a, 8kw, 1PH-240v

*Amp draw can vary 10% of rated draw at rated voltage. Current imbalance of 5% is acceptable*
  - 13. Connect motor on contactor test window and operate
    - a. Check rotation
    - b. Check for seal leaks
    - c. Amp draw test: wash motor:
      - 9 amps, (3PH-208v)
      - 8 amps, (3PH-240v)
      - 15 amps (1PH-208v)
      - 14 amps (1PH-240v)

- d. Pressure test: Wash pump 6min-7max psi lower base,
      - lower 8min-9max psi upper base, rotation 60 rpm
      - upper 10 seconds final rinse\_\_\_\_sec.

Final rinse 20 psi (adjust at pressure reg.) Rotation: 60 rpm (visually check)
  - e. Check for leaks with machine running
  - f. Overloads will operate in test mode
  - 14. Control box cover fits square and straight, no pits or burns
    - a. Door will latch open and slide closed easily
    - b. Front skirt of machine: straight
  - 15. No leaks from inlet plumbing, final rinse mixing chamber, or drain manifold
  - 16. Water control Weight are free moving, no contact with retaining bracket
    - a. Micro switch mounted flush to flipper lever
    - b. Micro switch tested and marked: 6.5 oz
    - c. Weights: 238 grams test
    - d. Water cut off level is 3/8" from weight's top
    - e. Weight's retaining bracket is installed and tightened (no contact with weight itself)
    - f. Operate flipper 10 or 15 times, should not stay on when tank is full
  - 17. Name plate with correct serial number
  - 18. Decals: electrical source, NSF data plate, wire diagram, temperatures, controls, safety, rotation, labels in control box. (all decals put on straight)
  - 19. General appearance and cleanliness (free of scratches or marks)
  - 20. Check all wire connections: tight, no crimps on insulation
  - 21. Check door cut off switch adjustment
  - 22. End caps welded correctly
    - a. 4 point welds on casting
    - b. All pins flash welded on only one side
    - c. Latch holds without binding
  - 23. Check cycle light operation
  - 24. Final rinse arms alignment correct, rotation must be 55 min / 70 max rpm @ 20psi
  - 25. High Potential test: 1700 volts @ 60 seconds
  - 26. Check all wires for loose connection
- Special Notes:**
- Make sure door moves up and down smoothly and Rinse jets are set to correct fan pattern
  - End caps close and open securely
- I certify the above items have been checked and meet or exceed established American Dish Standards:**

Inspector's Name \_\_\_\_\_