

CONVERSION TO CORNER KIT 088-1062 Models AFC3D, AFC3DS, AFCES, L3DWCS

Read all of the instructions first and verify you have all the parts needed before starting your conversion.
If you have any questions please call 1-800-922-2178.

ALL REFERENCE TO LEFT OR RIGHT IS GIVEN AS IF LOOKING AT THE FRONT OF THE CONTROL BOX
(except Solid Chemical model)

Remove the corner lever arm and linkage hardware from the machine including the two lever arm pivot weldments.

Remove safety cut-off switch and bracket from the back of the machine. CAUTION: The lever arm spring is under tension—use caution during removal.

Remove the door and door guides from the front, use all existing hardware and fasteners.

Unbolt and remove the "dummy door" panel from the left side.

ORDER OF ASSEMBLY

DUMMY DOOR PANEL: Converting to straight, you will place the panel over the door opening on the front of the hood.

LEVER ARM SUPPORT BRACKET: Install the two lever arm brackets on the back vertical panel of the hood. There are holes provided for mounting of various models (see drawing), including nuts and bolts to seal the opening. Use these fasteners to mount the brackets.

LEVER ARM: Install the lever arm, including the spring extensions (bushing mounted rods with hooks on the bottom end). With the lever arm in the 'doors-down' position, the bushing tabs, which are welded to the lever arm, should be pointing up and the extensions should be hanging over the outside of the lever arm (refer to picture).

DOOR SPRINGS: Place the springs (two springs for Inline) on the extension hooks. Place the secondary extension ("C" hook: 4" for 3D, 5" for 3DS and L3DWS, 7" for ES models) on the bottom of the spring and through the eyebolt. Then pull the eyebolt down through the hole in the frame located directly under each spring assembly. The ADS tool #88-1052 simplifies the pulling down and threading of the eyebolt. A 5/16 nut is used to secure the eyebolt. CAUTION: Lubricate the threads and DO NOT turn the nut under tension ---it can cause locking of the threads.

DOOR GUIDES: Install door guides on the open door. Leave bolts loose. Put the door on, but do not attach to the lever arm linkage yet. The door should be centered over the door opening and laying flat across the top of the machine. Tighten the rear guide. Now, slide the forward door guide next to the door with 1/8" free play and tighten the four bolts securing the door guide. NOTE: both doors should now move up and down freely without binding. The doors and guides must be parallel to each other. There should be a 1/16" to 1/8" play between door and the two guides.

DOOR LINKS: Install doors, door links, doorstops, and connect links to lever arm.

ADJUST DOORS: The (canti) lever arm should hold the door in the open position as well as in the closed position. If the doors droop down from full-up position, you need more of the eyebolt threads extending below the adjusting nut. If the doors won't stay down, you need less of the eyebolt threads below the nut. UNEVEN DOORS: the bent tubing of the lever arm is the cause of alignment. The lever arm must be bent further to even out the alignment. Hold one side down while lifting on the other until the doors are even.

DOOR CUT-OFF SWITCH: For the Inline configuration, the switch is mounted over the left side of the lever arm. There are two holes for the door switch on the back of the hood, above the lever arm bracket holes. Mount the switch bracket on these holes (see drawing). The 'L' lever goes on the spring extension bushing bolt and acts as the stop for the cut-off switch's plunger. The lever blade points outward. The orientation of the switch plunger wheel is at a right angle to the lever arm. Four screws holding the plunger head can be removed and rotated 90 degrees.

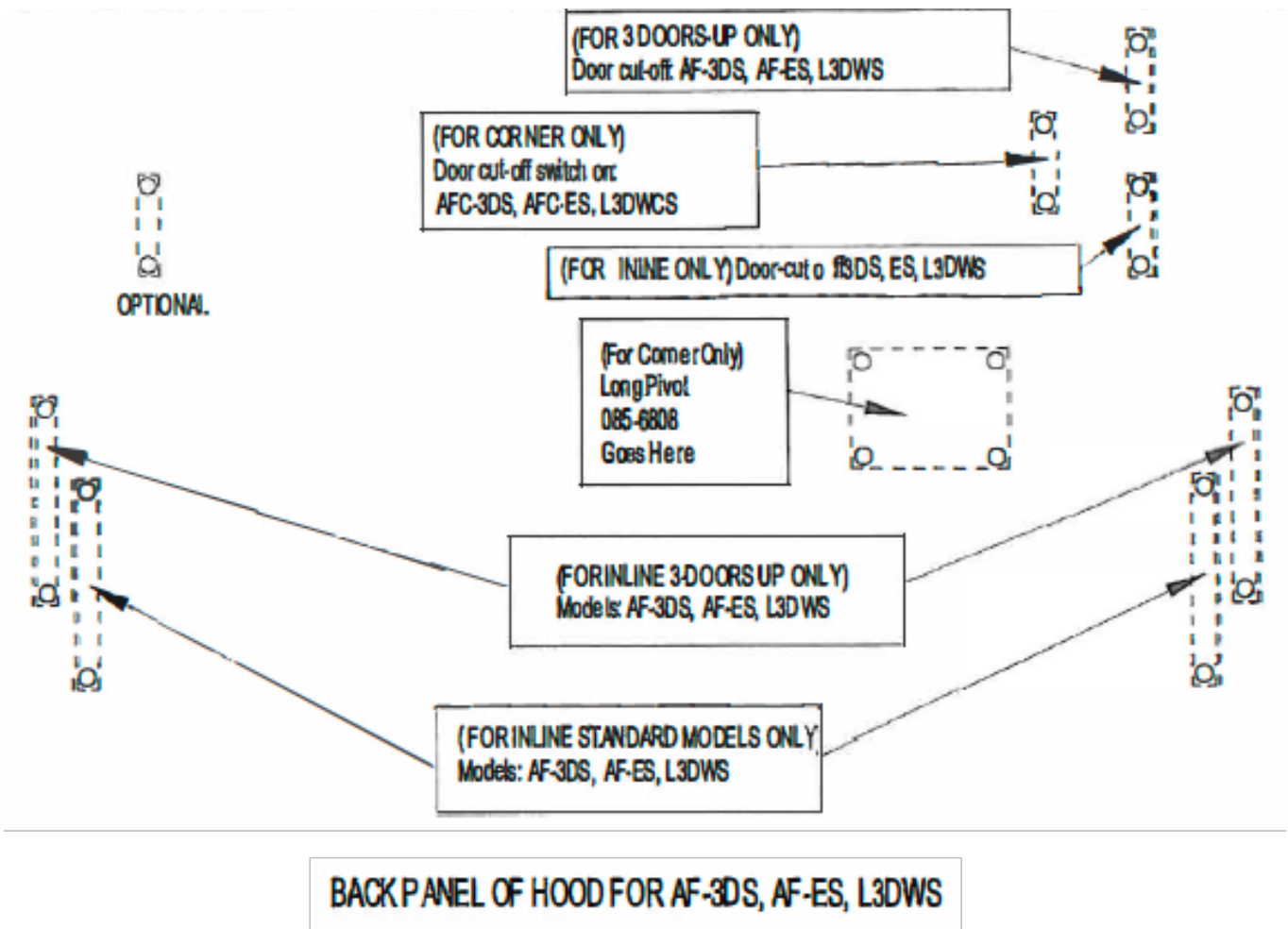

Ref. No.	Part No.	No. Req.	Description
1	085-6701	2	Spring Extension, Weldment
2	098-4002	2	Bushing, Bronze
3	098-1514	2	Bolt 5/16-18 x 1 1/2" HH SS
4	098-2505	2	Nut, Cap, 5/16-18
5	085-6703	1	Bracket, Lever Arm Support LH
N/S	085-6707	1	Bracket, Lever Arm Support RH
6	098-1423	4	Bolt, 1/4-20 x 1/2" HH SS
7	098-2404	10	Washer, 1/4" SS
8	098-2507	4	Nut, Lock, 1/4-20 SS
9	085-6726	1	Lever Arm (universal inline)
10	098-1431	2	Bolt, 1/4-20 x 1 3/8" HH SS
12	084-6703	4	Bushing, Dowel SS
14	098-1432	2	Bolt, 1/4-20 x 1 3/4" HH SS
17	098-2405	4	Nut, Cap, 1/4-20 SS
18	098-3003	2	Spring, Door
20	098-1581	2	Bolt, Eye, 5/16-18 x 6"
21	098-2502	2	Nut, 5/16-18 HH SS
22	099-1018	2	Cap, Lever Arm (black plastic)
23	086-6623	1	Bracket, Lever Arm Cut-Off (L Bracket)
N/S	098-2503	2	Washer, 5/16" Copper
19	086-6703	2	¹ Spring Extension, Secondary, "C" Shaped - 4" OA
19	086-6737	2	² Spring Extension, Secondary, "C" Shaped - 5" OA
19	086-6738	2	³ Spring Extension, Secondary, "C" Shaped - 7" OA

¹CAUTION USE ONLY FOR AF-3D MACHINES

²CAUTION USE ONLY FOR AF-3D-S, L3DWS

³CAUTION USE ONLY FOR AF-ES MACHINES

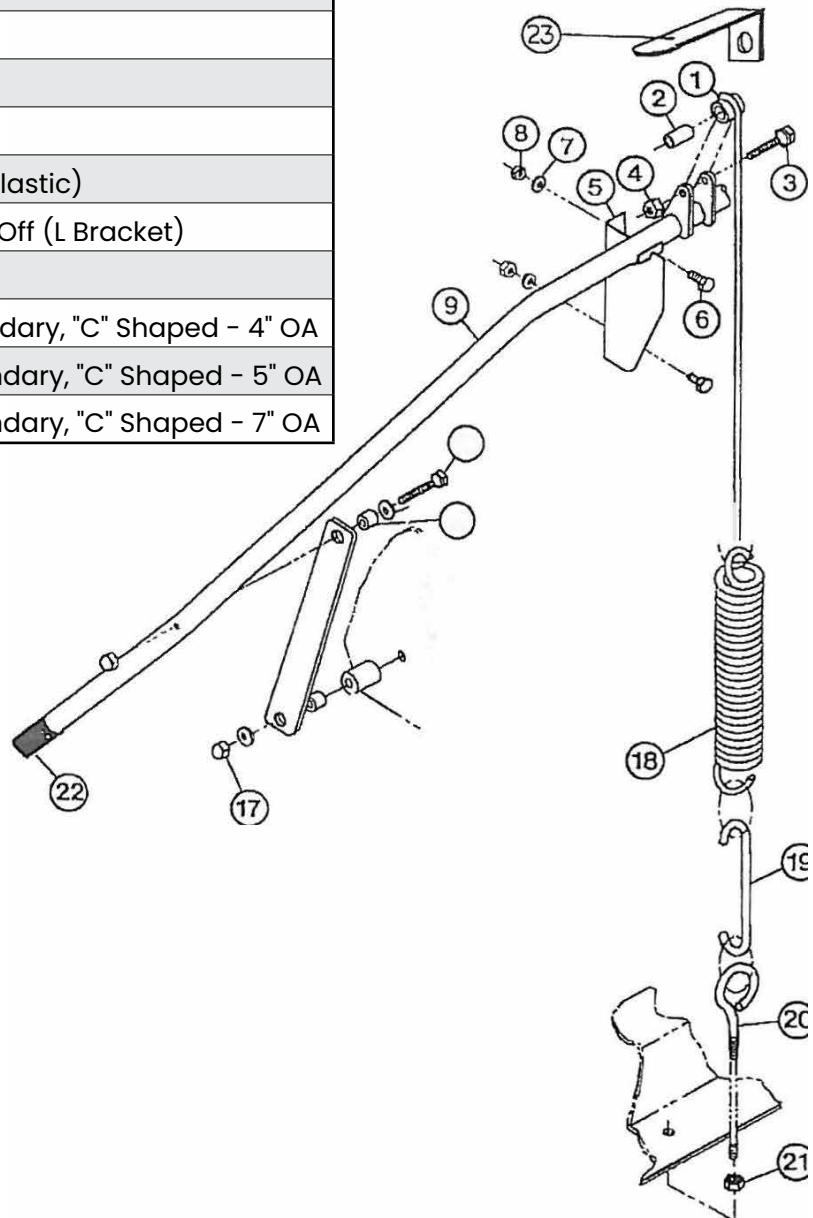



American Dish Service

**Manufacturer of low and high temperature Commercial
Dishwashers and Glasswashers**

© American Dish Service

900 Blake Street | Edwardsville, Kansas, 66111
913.422.3700 | Toll-Free: 800.922.2178 | Fax: 913.422.6630
orders@americandish.com | **americandish.com**

