

CONVERSION TO CORNER KIT 088-1061 Models AF3DS, AFES, L3DWS

Read all of the instructions first and verify you have all the parts needed before starting your conversion.
If you have any questions please call 1-800-922-2178.

ALL REFERENCE TO LEFT OR RIGHT IS GIVEN AS IF LOOKING AT THE FRONT OF THE CONTROL BOX
(except Solid Chemical model)

Remove the Inline lever arm and linkage hardware from the machine including the two lever arm support brackets on the rear of the hood. Remove safety cut-off switch and bracket from the back of the machine. CAUTION: The lever arm springs are under tension-use caution.

Remove the door and guides from the left side. Re-use all existing hardware and fasteners.

Unbolt and remove the "dummy door" panel from the front of the hood.

ORDER OF ASSEMBLY

DUMMY DOOR PANEL: Install the dummy panel over the vacant door opening on the left side. The panel is pushed to the back corner and the top edge must be flat on the hood before tightening.

LEVER ARM PIVOTS: There are holes provided for mounting on the back of the hood and on the dummy door, with nuts and bolts to seal the opening (see drawing and photo). Use these fasteners to mount the pivot plates when the time comes. Slide the pivot plates onto the corner lever arm pivot dowels with the long pivot bushing towards what will be the back of the hood. The long pivot's purpose is to clear the spring linkage.

CORNER LEVER ARM: Put the corner lever over the top of the machine and slide into place with the short pivot plate in place on the arm; long pivot should be bolted in place on the back wall of the hood first. The extension mounting bar (welded to lever) should be pointing up. The corner spring-extension ('dog-leg') should be installed to the bar with the copper washer and cotter pin. The extension will hang between the lever arm and the back of the machine, with the hook hanging downward, see photo. After the arm is in place, bolt the pivot short plate to the dummy door panel.

DOOR SPRING: Place the single large spring for corner on the spring extension hook. Place the existing secondary extension (C-hook) on the bottom of the spring and through the eyebolt. Then pull the eyebolt down through the hole in the frame located directly under spring. The ADS tool #88-1052 simplifies the pulling down and threading of the eyebolt. A 5/16 nut is used to fasten the eyebolt.

CAUTION: Lubricate the threads and DO NOT turn the nut under tension-it can cause locking of the threads.

DOOR GUIDES: Install the two existing left door guides on the front door opening. Push the door guides apart from each other and tighten bolts. NOTE: both doors should now move up and down freely without binding. The doors and guides must be parallel to each other. There should be a 1/16" to 1/8" play between door and the two guides.

DOOR LINKS: Install doors, door links, doorstops, door brace, and connect links to lever arm.

ADJUST DOORS: The cantilever arm should hold the door in the open position as well as in the closed position. If the doors droop down from full-up position, you need more of the eyebolt threads extending below the adjusting nut. If the doors won't stay down, you need less of the eyebolt threads below the nut.

UNEVEN DOORS: the bent tubing of the lever arm is the cause of alignment. The lever arm must be bent further to even out the alignment. Hold one side down while lifting on the other until the doors are even.

DOOR CUT-OFF SWITCH: For the Corner configuration, the switch is mounted above the long pivot plate, which is mounted on the back wall of the hood. Mount the switch bracket in the two holes located there. The plunger rides on the arm; the 'L' lever is not used. The orientation of the switch plunger wheel is parallel to the lever arm. The four screws holding the plunger head can be removed and the head rotated 90 degrees.

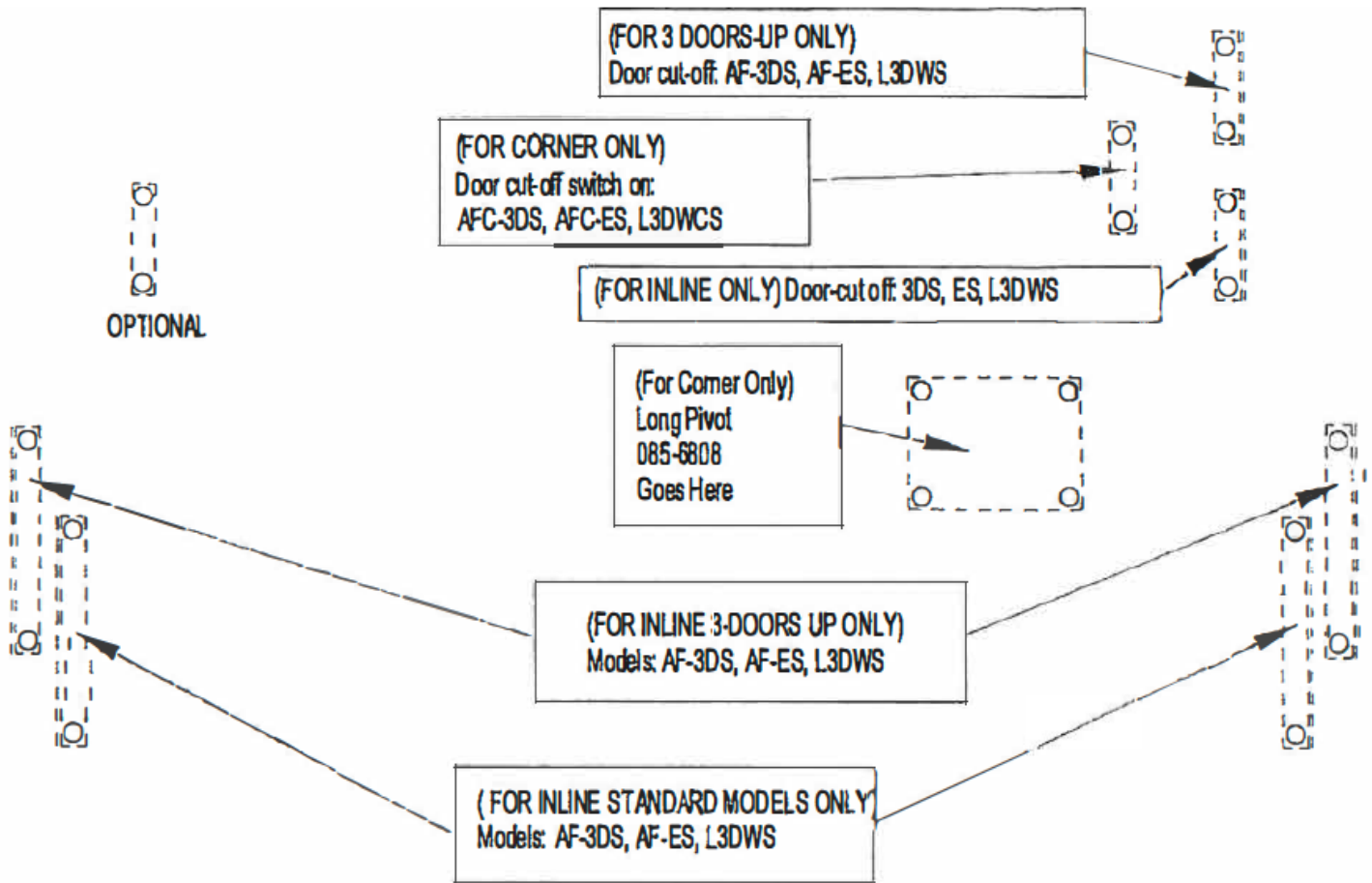
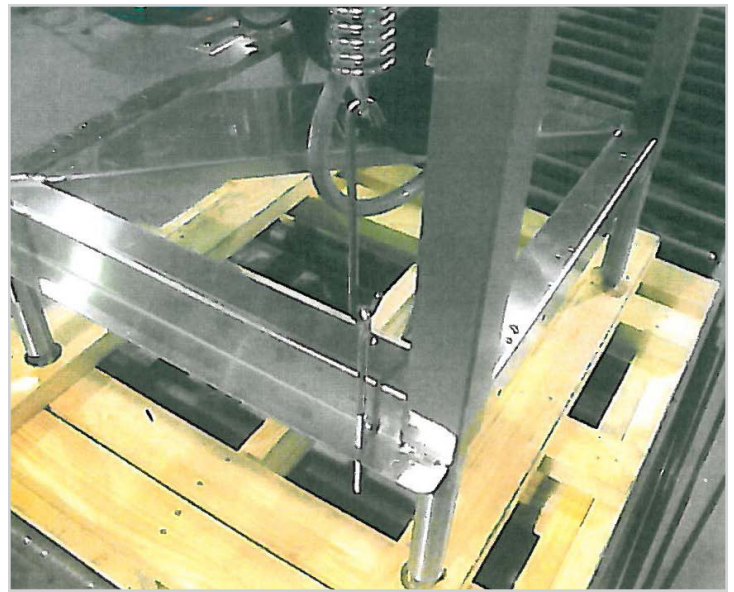
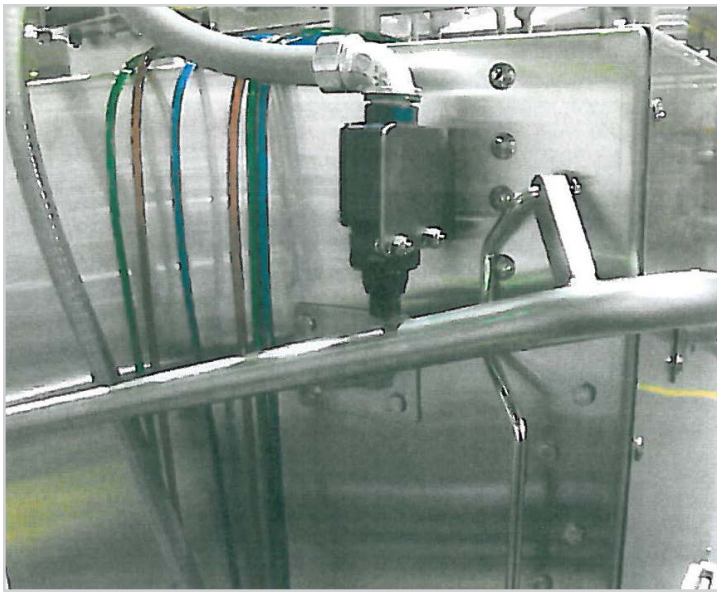

BACK PANEL OF HOOD FOR AF-3DS, AF-ES, L3DWS

Ref. No.	Part No.	No. Req.	Description
1	085-6808	1	Bkt, Lever Arm Pivot, Corner long/RH (long, plumbing side)
2	085-6807	1	Pivot, Lever Arm, Left (short)
3	098-2507	8	Nut, Lock, 1/4-20 HH SS
4	098-2404	12	Washer, 1/4" SS
5	098-1423	8	Bolt, 1/4-20 x 1/2" HH SS
6	085-6725	1	Lever Arm
7	098-8006	1	Pin, Cotter, SS
8	085-6721	1	Spring Extension, Corner - New R
9	098-3011	1	Spring, Door (corner)
11	098-1581	1	Bolt, Eye 5/16 x 6 11 (spare)
12	098-2502	1	Nut, 5/16-18 HH SS (spare)
13	092-1086	2	Cap, Lever Arm (black plastic 1")
15	098-2405	4	Nut, Cap, 1/4-20 SS
17	084-6701	4	Bushing, Dowel SS (5/8")
19	087-6701	2	Door Brace
20	098-1434	4	Bolt, 1/4-20 x 2" HH SS
22	098-2503	1	Washer, 5116" Copper

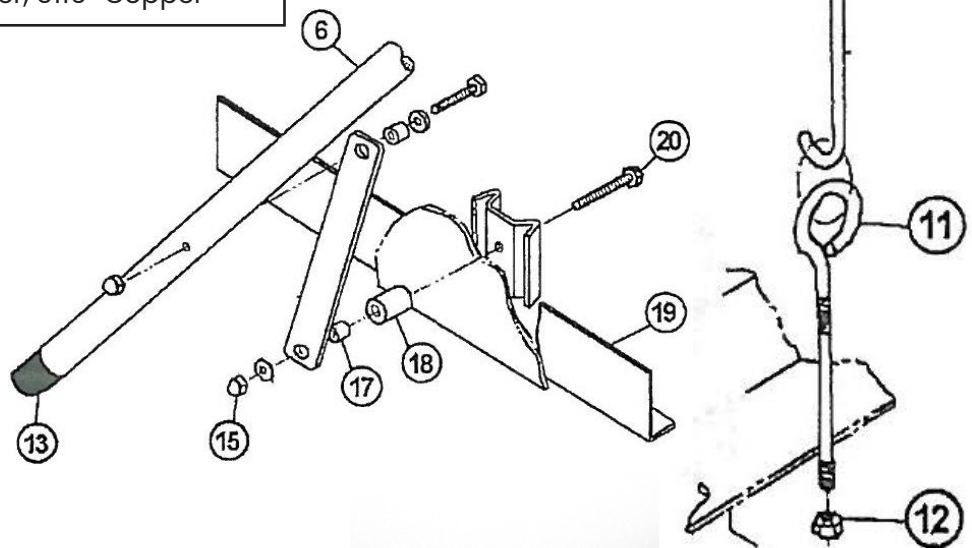
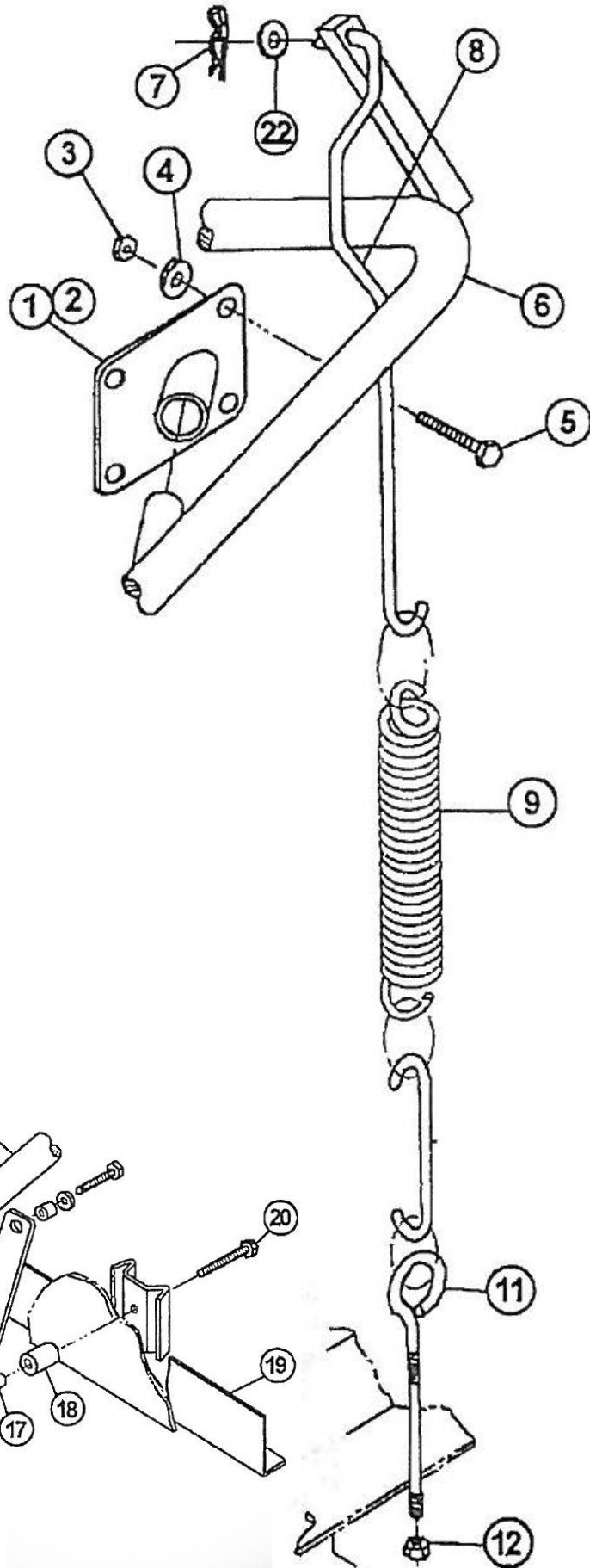



American Dish Service

**Manufacturer of low and high temperature Commercial
Dishwashers and Glasswashers**

© American Dish Service

900 Blake Street | Edwardsville, Kansas, 66111
913.422.3700 | Toll-Free: 800.922.2178 | Fax: 913.422.6630
orders@americandish.com | **americandish.com**

